

**Sluice / Gate Valve
with Electric / Pneumatic / Hydraulic Actuator**

**9650/9660
9670 SERIES**



YES. WE CARE...

SUDE

Sluice / Gate Valve

with Electric / Pneumatic / Hydraulic Actuator

Index

Introduction	01
Cast Iron Sluice Valves	02
Typical View of Gate Valve	04
Part List of Gate Valve	05
Typical Applications / Accessories	07
Specification of Electro Pneumatic Positioner	09
Hydraulic Cylinder	09
Electric Actuators	10
Control Panel Specification	11
GA Drawings	12

Introduction - Sluice / Gate Valve

Many types of valves have been invented by man to control the flow of fluids. Of those which have survived the test of time, each has at least several features which are unique or important. One offers tight shut-off, another low cost, others effective control of the fluid flow, still others, perhaps combinations of these, and on and on. To date, however, no valve inventor has discovered the ideal valve which combines all these features into one package and experience teaches us that it is unlikely anyone will.

Thus, valve designers have created the globe, plug, ball, gate and numerous other valve types, all of which are in extensive use throughout the world's vast and industrial processes. The gate valve is among the most common because it offers several advantages of function and cost effectiveness over other types. The Cast Steel Gate Valve has been tailored especially for the high pressure, high temperature water and steam services common to many electric utility, industrial and petrochemical applications. It offers all the advantages inherent in the wedge gate concept plus several novel design features.

Why a Gate Valve?

.Probably the single most important characteristic of a gate valve is the efficiency with which fluid flows through the valve. All valves must control fluid flow, meaning they must stop, regulate or allow fluid to pass through.

For the Majority of industrial and utility services, the conservation of fluid energy as it Moves through piping and valve are critical to efficient fluid control device.

As a result, the seat port or minimum opening through the valve will be smaller than for some other valve types having equivalent flow capacity, such as butterfly or globe. Since the seat port size has a major effect on valve cost, the gate valve has an important advantage in reducing valve capital expenses.



Gate valves also require only relatively moderate force to open or close and thereby require less manual operating effort or smaller power operators. The closure element is positioned perpendicular to the fluid flow regardless of flow direction. The force the stem must deliver to the closure element is essentially $F_x = mW$, Where W is the pressure load on the gate and m is coefficient of friction of the gate against the body seat. This compares to globes where $F_s = W$, so that the gate is only m (commonly 0.3) times the globe.

In addition, gates can be designed for high temperature and high pressure services through the use of proper materials and hard facings on seats and sliding components. Gates also are bidirectional and normally have similar flow characteristics in both directions.

Because of greater closure element travel however gate valves require a longer time to open or close especially compared to plug and ball valves, they are more subject to wear due to their slicing components tend to seal less perfectly than a properly designed globe or plug valve cannot combine stop and check functions, cannot replace an elbow in a piping system and are generally greatest in overall height requiring more installation space.

A Gate Valve, or Sluice Valve as it is sometimes known, is a valve that opens by lifting a round or rectangular gate/wedge out of the path of the fluid. The distinct feature of a gate valve is the sealing surfaces between the gate and seats are planar. The gate faces can form a wedge shape or they can be parallel. Gate valves are sometimes used for regulating flow, but many are not suited for that purposes having been designed to be fully opened or closed. When fully open the typical gate valve has no obstruction in the flow path resulting in very low friction loss.

Gate valves are characterized as having either a rising or non rising stem. Rising stems provide a visual indication of valve position. Non rising stems are used where vertical space is limited or underground.

Bonnets provide leak proof closure for the valve body. ure-tight seal. Union bonnet is suitable for applications requiring frequent inspection and cleaning. It also gives

Gate valves may have a screw-in, union, or bolted bonnet. Screw-in bonnet is the simplest, offering a durable, pressure-tight seal. Union bonnet is suitable for applications requiring frequent inspection and cleaning. It also gives the body added strength. Bolted bonnet is used

For larger valves and higher pressure applications. Another type of bonnet construction in a gate valve is pressure seal bonnet. This construction is adopted for valves for high pressure service, typically in excess of 15 MPa (2175 psi). The unique feature about the pressure seal bonnet is that the body-bonnet joints seals improve as the internal pressure in the valve increases compared to other constructions where the increase in internal pressure tends to create leaks in the body-bonnet joint.

Sluice valve / Gate valves normally have flanged ends which are drilled according to pipeline compatible flange dimensional standards. Cast iron, cast carbon steel, gun Metal, stainless steel, alloy steels, and forged steels are different materials from which gate valves are constructed. Widely accepted by Municipal Corporations. Irrigation authorities. Water supply authorities and Industrial users, these valves are designed as per latest editions of IS specifications and they bear ISI mark (for Non Rising Spindle Sluice Valves)



Cast Iron Sluice Valves

The Sluice Valves are strictly designed in accordance with IS: 780 and are used for different types of purposes, but mainly they are used for water works purpose. Our valves are ISI marked. They are available in different pressure designations PN0.4, PN0.6, PN1.0 & PN1.6.

Wedge vs. Parallel Slide

There are two basic types of gate valves in common use today for high pressure-temperature water and steam service, the wedge and parallel slide. The Wedge gate concept has been selected for its Equiwedge Gate Valve because for several functions advantages. The wedge of course is one of the earliest of machines and the first prehistoric man to apply the wedge as a chisel or means of splitting logs was indeed someone to respect. Undoubtedly he did not understand the mechanic but nevertheless applied the idea.

In wedge gate valves both the idea and an understanding of the mechanics have been applied effectively. Herein lies the major difference with the parallel slide that is the presence of wedging force.

It should be understood that this wedging force is added to the primary fluid pressure force acting on the gate. Extensive laboratory tests at Rockwell have demonstrated the advantage of this extra loading in achieving superior seat tightness. Test valves sealing marginally with fluid pressure loading in always showed improvement and often attained drop tightness with the extra stem loading.

If the design cannot accommodate the wedging, however it can become a disadvantage. Extremely high force generated by the wedge must be accompanied by a rigid body which will sustain these forces without harmful stresses. Also inadequate wedge flexibility can cause sticking, particularly when thermal effects or external pipe loads are present. The two piece wedge has a high degree of flexibility to accommodate such conditions within safe operating limits.

Another advantage of the wedge gate valve as compared to the parallel slide is minimized seat rubbing and scuffing during opening and closing. While closing a wedge gate any pressure load on the gate is carried by the gate guide system until the final increment of seating travel. This is only some 5% of the total gate travel.

By Comparison the seats of most parallel slide valves carry the gate load through essentially all of the travel. In Parallel slide valves due to high differential pressure a very high stresses develop especially on the body seats, accelerating wear and possibly causing galling damage to the seal surfaces. For this reason, parallel slide valves commonly require a bypass valves to equalize the pressure across the gate before opening.

The quality level of the product line is premium throughout and extensive use has been made of hard facings on critical seal and wear surfaces. All wedge and body seats as well as the bonnet backseat are inlayed with cobalt hard facing. The body pressure seal area is inlayed with special type stainless steel to assure material soundness and provide a corrosion resistant zone for effective sealing and ease of field bonnet disassembly. Another premium feature is the additional hard facing of the rails for the wedge guide system. Both the body and wedge guides are precision machined the wedge rails hard faced and then finished to assure smooth guiding throughout the life of the valve. Standard valve materials such as carbon steel grade WCB and low alloy WC6 and WC9 are available for high temperature service.

The Wedge

The seal element is the heart of any valve. For this reason a large part of the development effort has been directed toward the wedge. It was recognized that wedge flexibility-that is a high deflection index-was essential for good seal ability and freedom from wedge sticking a problem all too common to wedge gates.

Why is flexibility important? All valves in high pressure-temperature service, whether gate or any other type are subjected to forces caused by external loads imposed by the connecting piping and thermal effects caused by temperature changes. A rigid body shape will minimize the seat deformation produced by these forces but the cost effectiveness of material added to increase rigidity is not attractive.

Therefore flexibility must be designed into the wedge to accommodate these distortions in the body seat area. It should be noted that distortion in the context becomes harmful only when the performance of the valve is affected for example the valve leaks or cannot be

Cause and effect

Having discussed the problem in general let's look at it in more detail. The causes of body seat distortion are largely from piping induced loading and thermal changes in the valve body either non-uniform or uniform. Piping induced loadings can be bending compressive tensile or torsion type or the most probable a combination of several of these. They are the result of expansion or contraction of the piping system during heat up or cool down as well as the weight of the piping and attached components.

Temperature-induced forces are sometimes the result of non-uniform or localized temperature changes in the valve body. These are caused by varying wall thicknesses, localized heating such as welding the valve in the line, thermal shock, and the way insulation is applied and other similar factors, most of which are uncontrollable.

Operational procedures can produce thermal and pressure differentials which also cause dimensional changes in the body seat region. When a valve is closed hot and allowed to cool, components contract of varying rates and amounts. The absence or presence of the line pressure when the valve is closed adds another load source.

Regardless of the cause the effects of these forces on the body seat geometry can be several. The seat angle can increase or decrease or the plane of either body seat can rotate about one or more of its axes.

The gate opening – that is the distance between the seats-can expand or contract. The other major effect is that of the body seats losing their flatness in one or several localized areas across the seat faces.

The order of magnitude of these distortions determines the degree of seat leakage or wedge lock up but in the ideal wedge flexibility is adequate to accommodate the worst case within satisfactory working stresses. This is a tall order and numerous attempts have been made by valve designers to accomplish this

Typical View of Gate Valve

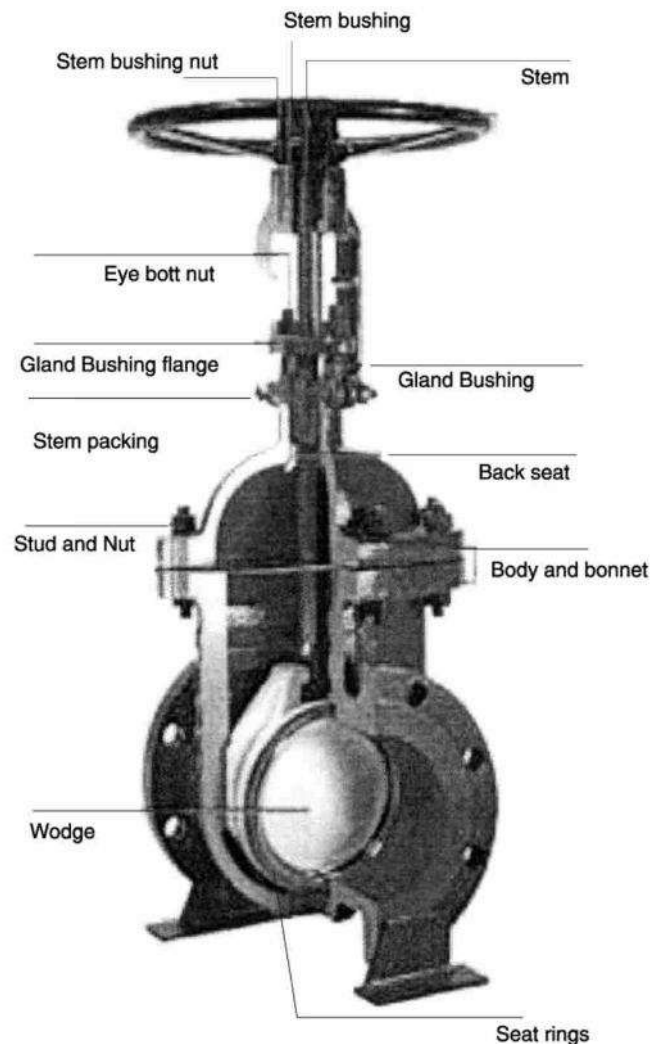

Gate Designs

The simplest wedge gate is the solid wedge, it is used in some designs of high pressure-temperature steel gate valves, but its useful flexibility is very limited. For this reason an "H" design is more common.

The "H" shape is achieved generally by casting a groove around the outside periphery and leaving a connecting hub in the center. This provides for relative bending between the wedge valves, which is needed to adjust for body seat angle changes. The degree of bending varies significantly with individual designs. In all cases, however the center hub acts as a connecting link between the wedge "halves" and severely limits the freedom of the wedge to make the necessary adjustment. If the hub is made small enough to permit adjustments of any magnitude, stresses in the hub can exceed the yield strength of the material. A large hub on the other hand diminishes the desired flexibility of the wedge "halves".

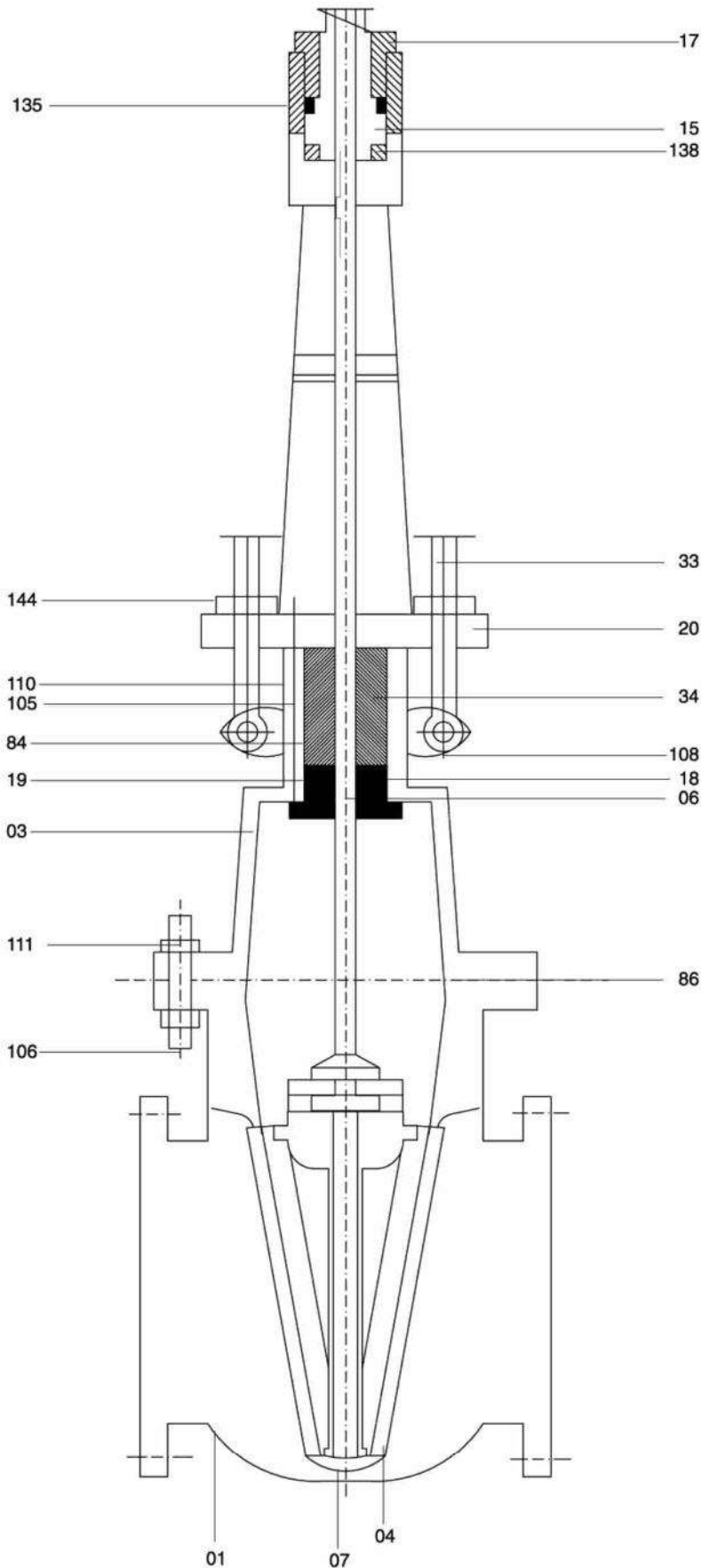

Sl. No.	Description
1	BODY
3	BONNET
4	GATE
6	STEM
7	SEAT RING
9	YOKE
15	STEM BUSHING
17	STEM BUSHING NUT
18	BACK SEAT BUSHING
19	LANTERN
20	GLAND FLANGE
33	GLAND EYE BOLT
34	PACKING
84	GASKET
86	RING JOINT
105	BODY BONNET STUD
106	GLAND LUG STUD
108	YOKE STUD NUT
110	BODY BONNET NUT
111	HAND WHEEL NUT
114	GLAND LUG STUD NUT
119	GREASE FITING
135	BALL BEARING
143	NAME PLATE
138	GEAR OPERATOR / PNEUMATIC/ HYDRULIC/ ELECTRIC ACTUATORS

Hydrostatic Test Pressures

Availability	Size Range	Manufacturing Standard and Pressure Rating	Hydrostatic Test Pressures in kg/cm ²	
			Body	Seat
Standard Supply	50 to 1200 mm	PN 1.0	15	10
	50 to 600 mm	PN 1.6	24	16
Optional	700 to 1200 mm	PN 0.4	06	04
	350 to 1200 mm	PN 0.6	09	06

Material of Construction

	Body/Wedge/Dome	Body/Wedge/Rings	Spindle	Stem Nut
Standard Supply	Cast Iron	Leaded Tin Bronze	St. Steel as per IS:6603 Gr. 12 Cr 12	Leaded Tin Bronze
Optional	SG. Iron , Cast Steel	Stainless steel	High Tensile Brass; St. Steel as per	High Tensile Brass

Note: For special material of constructions, please contact us. We also supply valves with coating for sea water application.

End Connections

Availability	Flange Drilling Standard
Standard Supply	IS: 1538
Optional	BS 10, Table D/E/F BS En 1092.2 (BS:4504) 6,10 and 16 Bar IS:1538 Table 5 ANSI B 16.1/B16.5, DIN 2532 (10 Bar) IS:6392

Salient constructional features

- Combination of excellent design features of reputed overseas valve brands
- Rigid and sturdy design with minimum loss of head across the valve
- Perfect interchangeability of components
- Assured parallelism between wedge faces
- Perfect machining and pressing of body and wedge rings
- Excellent finish on spindle threads resulting in low friction and smooth operation of valves
- Long service life and leak-tightness even after thousands of open / close cycles.

Epoxy coating of valves

In considering the seriousness of corrosion due to water, effluent, sea water constituents in the atmosphere and corrosion due to soil and in the wide chemical industry. The bodies' bonnets, key caps and hand wheels of the Sluice / Gate Valve are being protected with fusion bonded epoxy which is electrostatic ally applied epoxy resin coated type on both internal and external surface. This superior coating process offers good corrosion resistance and long operational life.

Direction of Closure

All Sluice Valve and Gate Valve are closed in clockwise direction. Sluice Valve and Gate Valve that close in the anti-clockwise direction are also available. The closing direction of wedge is being marked using an arrow on each Valve's bonnet nut for easy identifications during plant/system operation.

Typical Applications

- Clear water having turbidity up to 5000 pm and temperature up to 45°C
- Other fluids with maximum pressure / temperature conditions within the limit.
- Valves can also be supplied up to 180°C working temperatures with special design, subject to working pressure limitations.
- Water works
- Sewage system
- Drainage system
- Fire protection system
- HVAC system
- Plumbing system
- Sanitary system
-

Accessories (optional)

- Position Indicator
- By-pass arrangement (200 NB and above sizes)
- Repacking (Back Seat) arrangement
- Spur / Bevel / worm gear arrangement(200 NB and above sizes)
- Thrust bearing arrangement (200 NB and above sizes)
- Channel and shoe arrangement (Renewable) (300 NB and above sizes)
- Locking arrangement
- Extension shafting and head stock
- Electric/Hydraulic/Pneumatic Actuator
- Drain Plug
- Chain and Chain Wheel arrangement

FOR TIGHT SHUT OFF THE SLUICE AND GATE VALVE CAN BE SUPPLIED IN RESILIENT SEATED CONSTRUCTION, FOR DETAILS REFER SUDE.

Accessories of Sluice / Gate valve

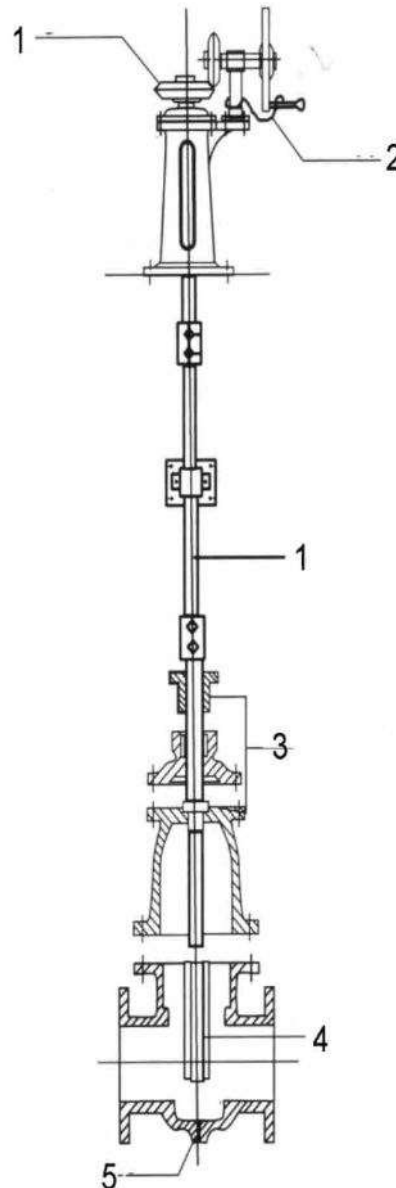

Sl. No.	Parts
1	Extension shafting/Head stock/ Bevel Gear arrangement
2	Locking arrangement
3	Back bush/Bushing arrangement
4	Channel and shoe arrangement
5	Drain plug

Actuation

All Sluice / Gate Valve are available in Rising and Non rising construction, the suitable Electric actuator/ Pneumatic cylinder / Hydraulic cylinder is selected and assembled based on the load and the process parameter.

Various types of cylinders are available for operating Knife gate valves. The most commonly used cylinders are operated by air.

In most designs, the valve stem serves as a piston rod, with the knife fastened directly to the actuator. Actuators with double ended piston rod option can be supply to install position indicator or limit switches and for connecting an emergency device for manual actuation of the valve.

Hand wheels and gear boxes can be mounted on top of the cylinders for emergency operation due to loss of operating medium in the cylinder.

If specified by the customer, Sude can offer the valves can be with mounting pads for most steel cylinders with Electro pneumatic positioners for throttling control.

TYPE OF ACTUATOR

Sude offers different types of Cylinder Actuator suitable for Valve. Cylinder Actuator is double acting design and is available in a wide range of cylinder diameter and stroke lengths, for details refer 1100 series literature.

- Standard Cycle duty Air cylinder up to 8 bar rated

Type : Double Acting

Cylinder size Range: 65 to 350mm and other respected to service condition

Rating: Suitable for normal operation with Air supply up to 8 bar.

ACCESSORIES :

Cylinder actuator also can be supplied with different types of accessories required for specific application and automation requirements.

MANUAL OVERRIDE:

Manual Override can be offered as hand operation facility with cylinder actuator. This is a very useful at the time of Air or Electric supply failure.

SOLENOID VALVE

- Type – 5x2 ways
- Body – Aluminum, Brass, S.S.
- Coil Voltage – 220 V / 110 V / 24 V.D.C. Weather Proof, Ex-Proof, IIA, IIB.
- Size – ¼ “to 1”

AIR FILTER REGULATOR OF:

¼ “to ¾ “NPT (F)

LIMIT SWITCHES:

Design – Mechanical, Proximity Switch

ELECTRO PNEUMATIC POSITIONER

I/P & O/P=4-20mA



Electro-Pneumatic Cylinder with Type Electro pneumatic Positioner

CYLINDER SPECIFICATIONS:

- **Maximum Working Pressure :** 150 psig Maximum
- **Working Temperature :** 80°C
- **Control Signal Pressure rang:** 3 to 15 psig [0.2 to 1.0kg/cm²]

AIR CONSUMPTION:

1 SCFM [1.76NMCH] of free air at 80 psig [5.6kg /cm²]

Thrust-available thrust may be considered as 70% of Cylinder bore area multiplied by operating air pressure.

The Electro pneumatic positioner is a digital field device with a highly integrated micro controller. The positioner consists of the following components: Casing and cover

PCB with corresponding electronics with or without communication via HART or with electronics for communication according to the PROFIBUS PA specification, IEC 1158-2 bus supplied device. Actuator travel detection system. Terminal housing with screw terminals. Pneumatic valve manifold with piezoelectric valve pre-control.

The valve manifold is located in the housing the pneumatic connections for the inlet air and the positioning pressure on the right hand side. A pressure gauge block and / or a safety solenoid valve can be connected there as option. The circuit board container in the casing

provides slots for separately ordered boards with the following functions.

IV module

Position feedback as two wire signal 4 to 20mA

Alarm module [3outputs, 1 input]:

Signaling of two limits of the travel or angle by binary signals. The two limits can be set independently as maximum or minimum values. Output of an alarm if the set point position of the final control element is not reached in automatic mode or if a device fault occurs. Second Binary input for alarm signal of for triggering safety reaction or for blocking / signaling function or safety position

Hydraulic Cylinder

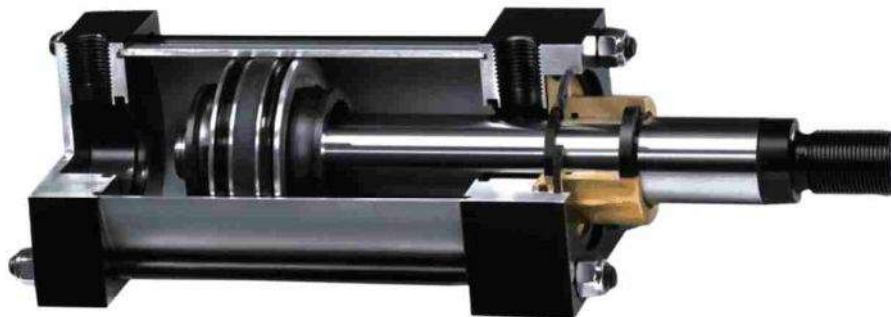

HYDRAULIC CYLINDER

1. High strength alloy steel piston rods toughened, accurately ground and hard chrome plated to ensure anti-corrosion and maximum life of bearings and seals.
2. Seamless drawn cylinder pipes are precisely honed to a fine finish internally to provide long life for piston seals and to prevent corrosion.
3. Piston and ram seals of bronze filled PTFE having very low coefficient of friction and anti-extrusion characteristics ensure perfect sealing with absolutely frictionless smooth movement.
4. Cartridge-type sealing concept for piston rods enables easy maintenance and replacement of seals without opening of cylinder end covers.
5. Piston and piston rod are supported with replaceable self-lubricating bronze filled PTFE bearings which provide accurate and smooth frictionless movement.
6. End covers are all fabricated and are of robust design to withstand heavy forces. Cold phosphatising is done for rust prevention prior to painting.
7. Wide varieties of mounting styles are available.
8. Tie rod design makes the cylinder rugged and maintenance easier.
9. INSPECTION: Hydrostatic Pressure testing of all hydraulic cylinders at maximum working pressure for leakages and guaranteed performance.

A complete hydraulic system can be supplied on request to meet the desired sluice/gate valve operating characteristics. These systems include the hydraulic cylinder, the hydraulic power unit, accumulators, and the necessary controls, and are usually furnished in self-contained units with all piping and wiring completed. The systems can range from the simple manual valve open-and –close application to the more complex system which will respond to a local or remote sensing device or signal. Systems can be supplied for electric or pneumatic control valve operation.

Electric Actuators

Motorized controls may be applied to valves of any size, for operation in practically any position or location. All units, whether installed directly on a valve on or a floor stand, can be manually operated in case of power failure.



The units are available with single and three phase Actuators and are sized for specified conditions of operation. Motor units are available with limit switches and push button controls which can be selected to meet customer's requirements.

SDTORK Electric Actuator can be directly assembled with the valve. The Actuator is basically a worm gear type reduction gear box. A single stage grease bath worm gear gives quietness and reliability in operation. The valve can be fully opened, fully closed or adjusted to Any intermediately position. The rectory force on the worm shaft which is a Floating one is directly proportional to the output torque and is absorbed by a set of disc springs. The lateral movement of the worm shaft under load, trip closes the Torque switch. The driving motor is a TEFC/TESC squirrel cage class induction motor combining low inertial with a high starting and stalling

coupling arrangement and fixing holes as per DIN 3210 for wall mounting.

Actuators with IP67 / 68 class protection are available on demand.

Three phase Actuators are fitted with Torque Limit switches & Travel Limit switches & also in built with Manual Hand wheel used for operating the Actuator in case of power failure. Actuator is supplied with various shafts Designs to suit Rising & Non-rising stem valve. All actuators can be supplied with various kinds of accessories to make system QCS/DCS/PLC compatible



Accessories for Actuators

- Travel Limit Switches – 2 nos
- Auxiliary Limit Switches – 2 nos
- Hand wheel for Manual operation
- Local position indicator
- Potentiometer for feed back
- Torque limit switches

The Actuators can be supplied with a panel having Auto Calibration facility.

Actuator can also be supplied with:

Single Phase OR Three phase Panel for switching the valve On/Off through Push Buttons for local operation under manual mode OR through PLC under Auto mode. Through 4-20mA, 0 to 10 V DC or up/down pulses. All this can also be supplied in integral mode.

Control Panel Specification :

- a) Input : Single Phase 230 V AC OR 3 Phase 415 V AC, 4 wire supply.
- b) Output supply: Single Phase 230 V AC OR 3 phase 415 V AC Reversible supply.
- c) Auto / Manual selection : Selector switch provided. In Auto mode open & close operation is controlled by 4-20mA Input & under Manual mode operation is through Push buttons.
- d) Indications : Zero to a100% valve position display, R, Y, B Phase Indication [applicable only for 3 phase] Open & Close, Fully open & Fully close indication.
- e) Main switch - Single Phase OR 3 Phase MCB for mains On / Off.
- f) Phase fail / error protection provided.
- g) Fuse protection provided for each phase.
- h) Protection from over torque - If Actuator gets over torque the torque switch trips & the system protects the motor. Also provided with 10 metres cable for Motor & Feed back with connectors.



Wall mounted control panel.



Integral Starter



Rising Valve with Pneumatic Cylinder of PN 0.6 Rating

SUDE

9660

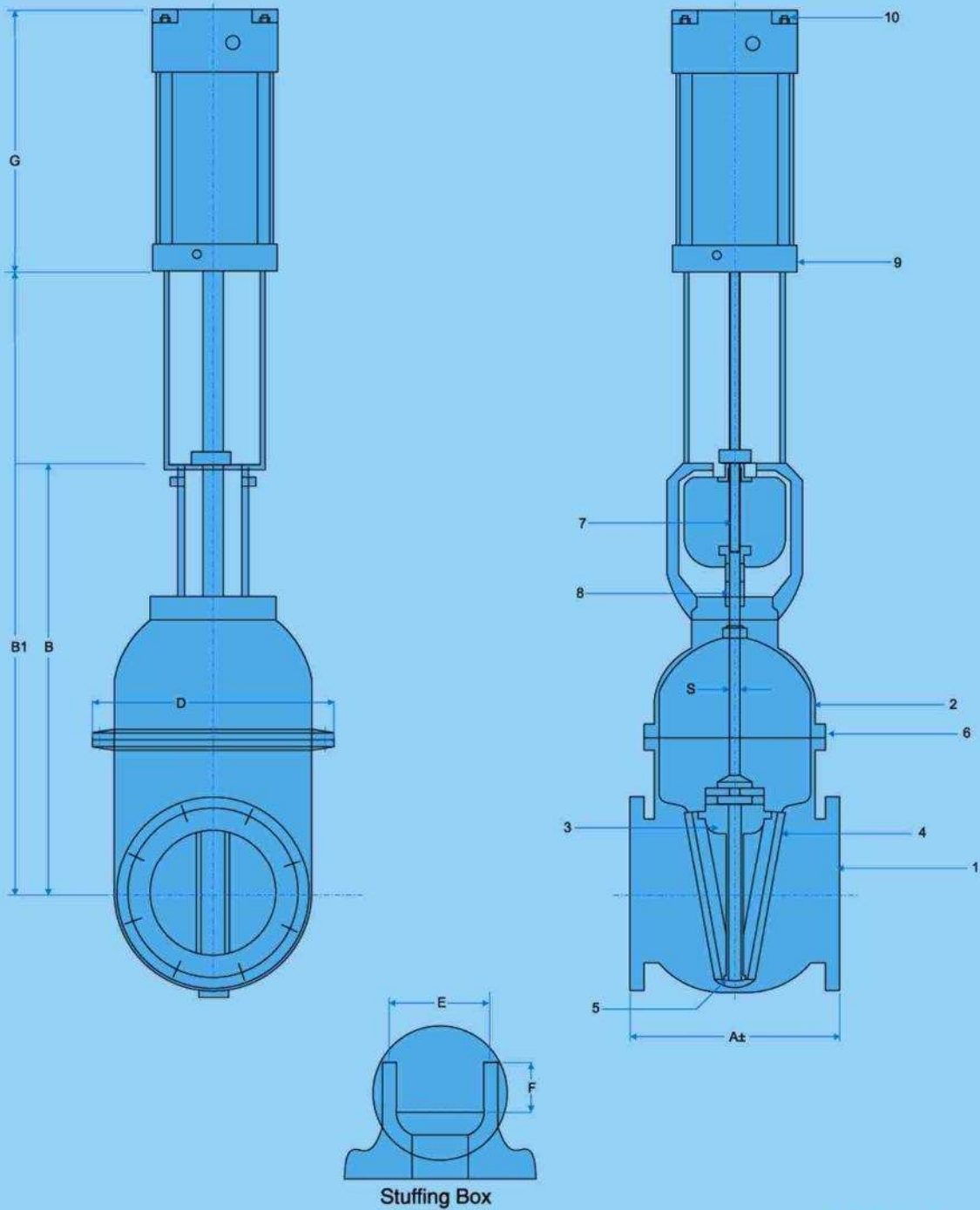

PART LIST

S.No.	DESCRIPTION
1	BODY
2	BONNET
3	WEDGE
4	BODY SEAT RISING
5	WEDGE FACE RING
6	BOLTS & NUTS
7	STEM
8	GLAND PACKING
9	CYLINDER
10	SCREW NUT

DIMENSIONS OF RISING VALVE PN 0.6 RATING

SIZE NB	ACTUATOR MODEL NUMBER	A±	Height (Approx)		Stem Dia.	Width	I.D. of stuffing box	Depth of stuffing box	G	Cv	WT. OF ASSY IN KGS.
			B (C)	B1(O)							
350	9660/350/PNCYL300/CI/GM/0.6/RU	435±3	1360	1750	39	650	64	51	636	13800	505.5
400	9660/400/PNCYL300/CI/GM/0.6/RI	470±3	1510	1940	43	700	68	51	686	18375	753.7
450	9660/450/PNCYL300/CI/GM/0.6/RI	505±3	1660	2100	47	750	72	51	736	23850	953.7

Rising Valve with Pneumatic Cylinder of PN 1.0 Rating

SUDE

9660

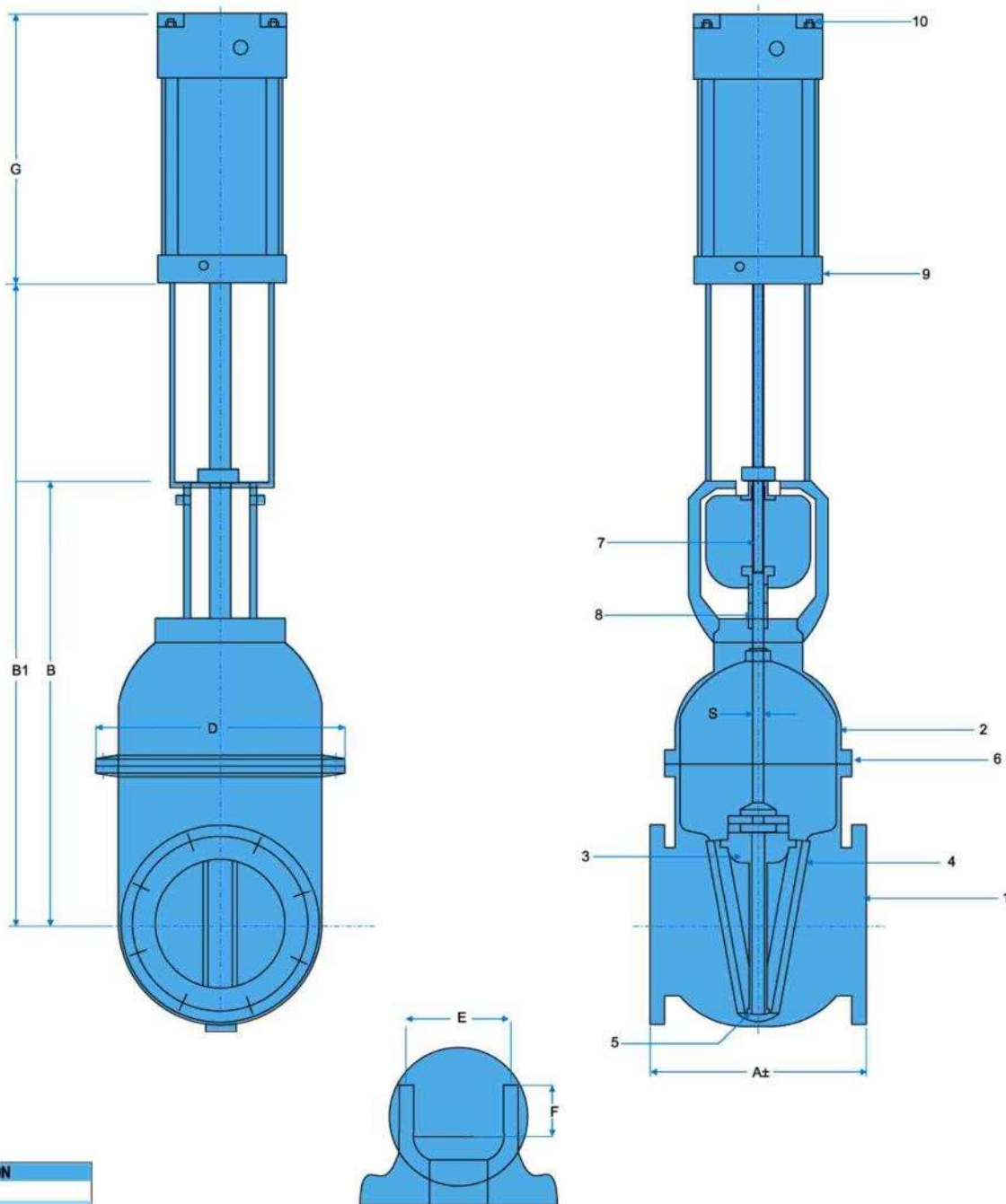

PART LIST

S.No.	DESCRIPTION
1	BODY
2	BONNET
3	WEDGE
4	BODY SEAT RISING
5	WEDGE FACE RING
6	BOLTS & NUTS
7	STEM
8	GLAND PACKING
9	CYLINDER
10	SCREW NUT

Stuffing Box

DIMENSIONS OF RISING VALVE PN 1.0 RATING

SIZE NB	ACTUATOR MODEL NUMBER	A±	Height (Approx)		Stem Dia.	Width	I.D. of stuffing box	Depth of stuffing box	G	Wall Thickness of body	Wall Thickness of bonnet	Cv	WT. OF ASSY IN KGS.
			B (C)	B1(O)									
50	9660/50/PNCYL75/CI/GM/1.0/RI	215	435	495	24	160	44	42	268	8.0	8.0	300	39.75
65	9660/65/PNCYL75/CI/GM/1.0/RI	230	510	585	24	200	44	42	268	8.5	8.5	335	44.1
80	9660/80/PNCYL100/CI/GM/1.0/RI	230	615	705	24	220	44	42	268	9.0	9.0	510	56.5
100	9660/100/PNCYL125/CI/GM/1.0/RI	255	620	730	28	250	48	42	268	10.0	9.0	945	78.2
125	9660/125/PNCYL150/CI/GM/1.0/RI	266	650	785	28	300	48	42	318	11.0	10.0	1525	104.5
150	9660/150/PNCYL200/CI/GM/1.0/RI	280	720	880	28	330	52	42	318	12.0	11.0	2250	137.1
200	9660/200/PNCYL250/CI/GM/1.0/RI	318	870	1080	32	460	56	51	460	13.0	12.0	4150	207.5
250	9660/250/PNCYL300/CI/GM/1.0/RI	355	1115	1375	36	495	60	51	460	14.5	13.5	6700	290.5

Rising Valve with Pneumatic Cylinder of PN-1.6 Rating

SUDE

9660

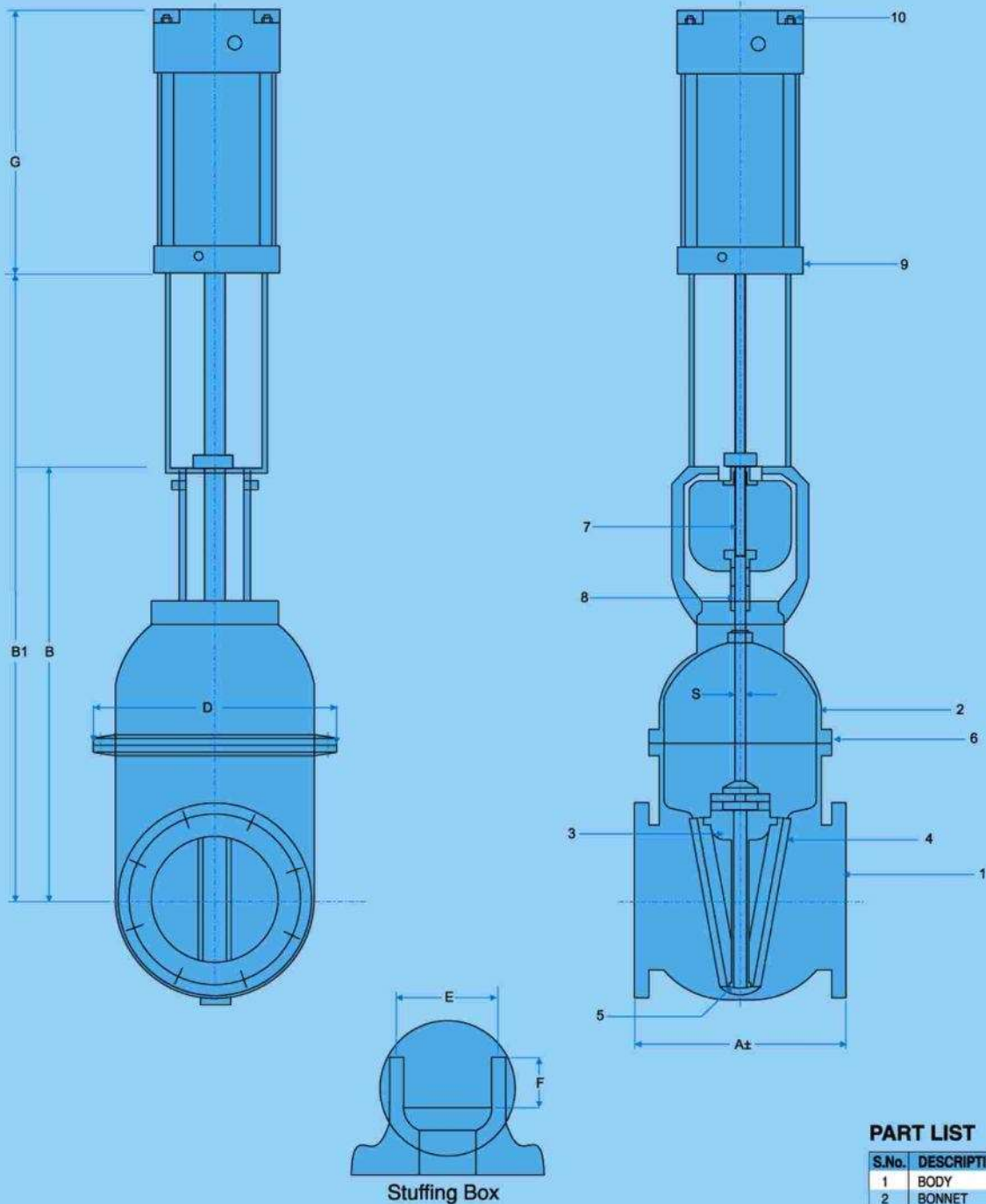

PART LIST

S.No.	DESCRIPTION
1	BODY
2	BONNET
3	WEDGE
4	BODY SEAT RISING
5	WEDGE FACE RING
6	BOLTS & NUTS
7	STEM
8	GLAND PACKING
9	CYLINDER
10	SCREW NUT

DIMENSIONS OF RISING VALVE PN - 1.6 RATING

SIZE NB	ACTUATOR MODEL NUMBER	A±	Height (Approx)		Stem Dia. S	Width D	I.D. of stuffing box E	Depth of stuffing box F	G	Wall Thickness of body	Wall Thickness of bonnet	Cv	WT. OF ASSY IN KGS.
			B (C)	B1(O)									
50	9660/50/PNCYL75/CI/GM/1.6/RI	215	435	495	26	190	50	53	268	8.0	8.0	300	39.75
65	9660/65/PNCYL100/CI/GM/1.6/RI	230	510	585	26	225	50	53	268	8.5	8.5	335	49.5
80	9660/80/PNCYL125/CI/GM/1.6/RI	230	615	705	26	250	50	53	268	10.0	9.0	510	63.2
100	9660/100/PNCYL150/CI/GM/1.6/RI	255	620	730	30	290	54	53	268	10.0	9.0	945	81.5
125	9660/125/PNCYL200/CI/GM/1.6/RI	266	650	785	30	325	54	53	318	12.0	11.0	1525	121.1
150	9660/150/PNCYL250/CI/GM/1.6/RI	280	720	880	32	350	56	53	318	13.0	12.0	2250	162.5
200	9660/200/PNCYL300/CI/GM/1.6/RI	318	870	1080	38	480	70	68	460	14.5	13.5	4150	247.5

Rising Valve with Hydraulic Cylinder of PN 0.4 Rating

SUDE

9670

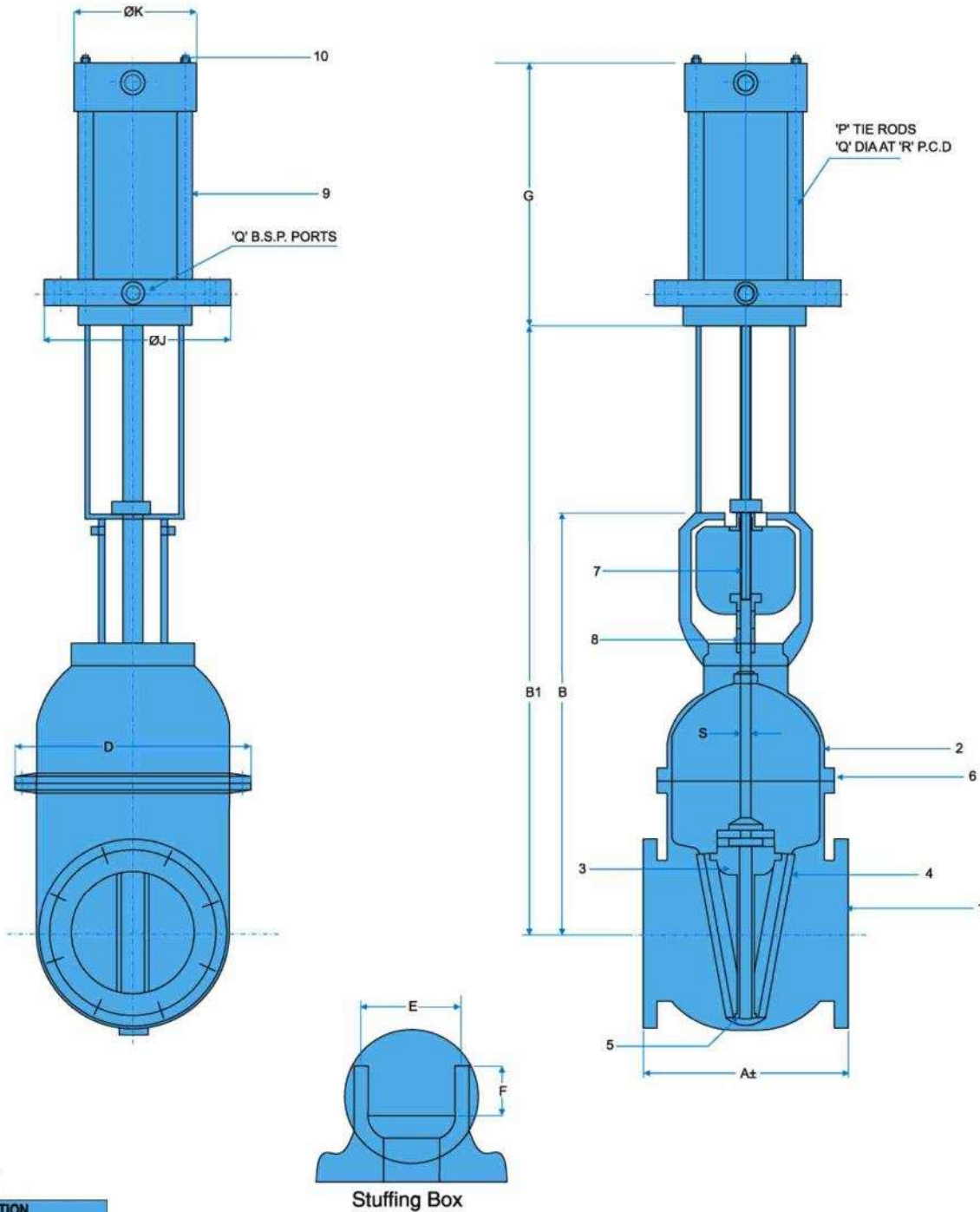

PART LIST

S.No.	DESCRIPTION
1	BODY
2	BONNET
3	WEDGE
4	BODY SEAT RISING
5	WEDGE FACE RING
6	BOLTS & NUTS
7	STEM
8	GLAND PACKING
9	HYDRAULIC CYLINDER
10	SCREW NUT

DIMENSIONS OF RISING VALVE PN 0.4 RATING

SIZE NB	ACTUATOR MODEL NUMBER	A±	Height (Approx)		Stem Dia.	Width	I.D. of stuffing box	Depth of stuffing box	G	K	J	P	Q	R	WT. OF ASSY IN KGS.	Cv
			B (C)	B1(O)												
700	9670/700/HCL100/CI/GM/0.4/RI	635±4	2360	3050	54	1050	83	59	253	180	265	6	20	141.5	2457.5	72800
750	9670/750/HCL100/CI/GM/0.4/RI	685±4	2560	3370	54	1200	83	59	253	180	265	6	20	141.5	2688.1	82235
800	9670/800/HCL125/CI/GM/0.4/RI	700±4	2760	3540	59	1250	92	67	263	210	295	6	20	172.5	3733.6	100000
900	9670/900/HCL125/CI/GM/0.4/RI	740±4	3050	3990	64	1350	97	67	263	210	295	6	20	172.5	4303.9	125000
1000	9670/1000/HCL150/CI/GM/0.4/RI	760±4	3250	4270	69	1470	102	67	270	251	350	6	24	204.0	4925.6	170000
1100	9670/1100/HCL200/CI/GM/0.4/RI	780±4	3340	4400	69	1550	102	67	285	315	415	8	24	267.0	5601.5	220000

Rising Valve with Hydraulic Cylinder of PN 1.0 Rating

SUDE

9670

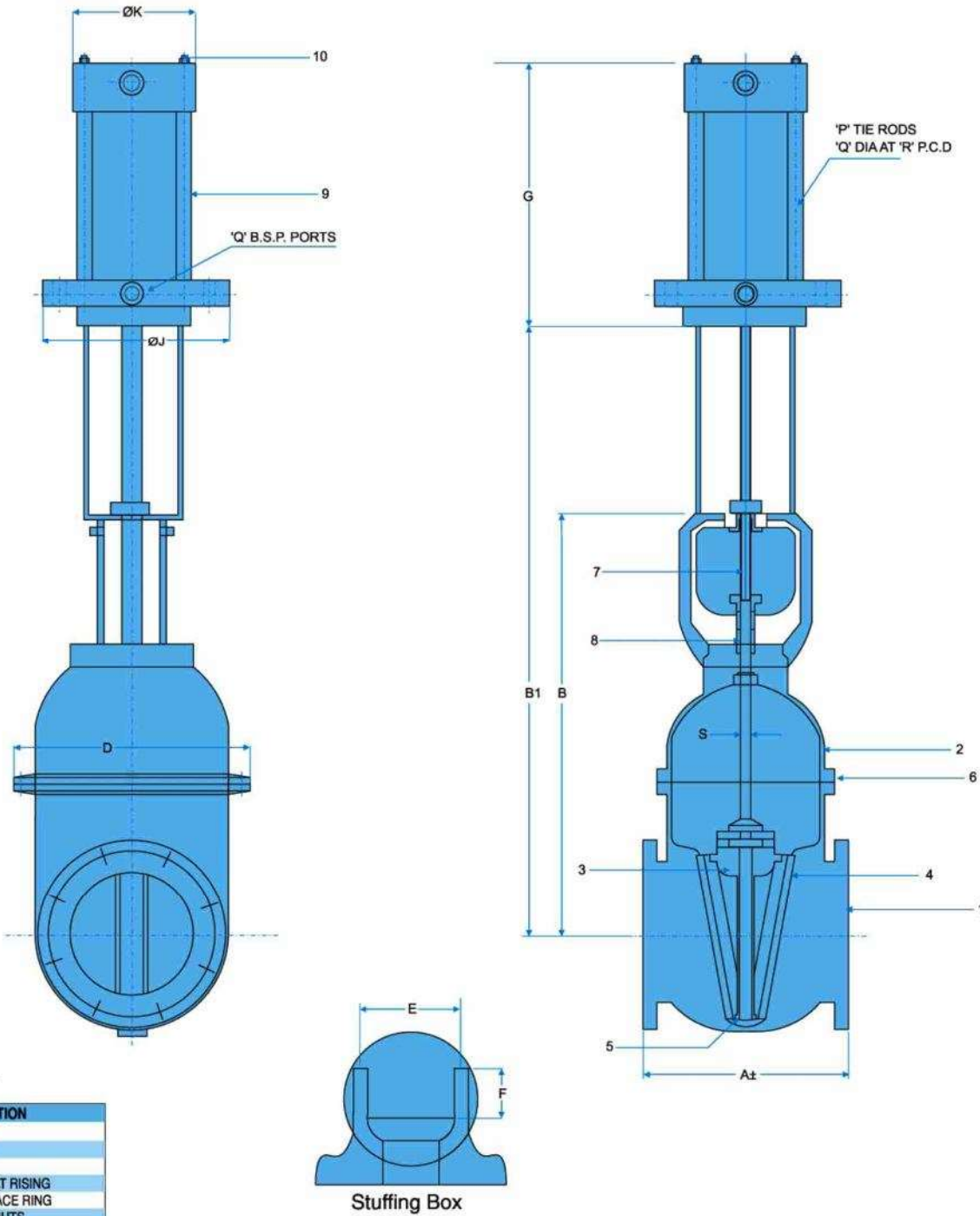

PART LIST

S.No.	DESCRIPTION
1	BODY
2	BONNET
3	WEDGE
4	BODY SEAT RISING
5	WEDGE FACE RING
6	BOLTS & NUTS
7	STEM
8	GLAND PACKING
9	HYDRAULIC CYLINDER
10	SCREW NUT

DIMENSIONS OF RISING VALVE PN 1.0 RATING

SIZE NB	ACTUATOR MODEL NUMBER	A±	Height (Approx)		Stem Dia. S	Width D	I.D. of stuffing box E	Depth of stuffing box F	G	K	J	P	Q	R	WT. OF ASSY IN KGS.	Cv
			B (C)	B1(O)												
350	9670/350/HCL75/CI/GM/1.0/RI	550±3	1480	1860	39	730	64	51	220	130	115	6	12	105.0	440.17	13800
400	9670/400/HCL100/CI/GM/1.0/RI	600±3	1680	2120	43	800	68	63	253	180	265	6	20	141.5	738.4	18375
450	9670/450/HCL100/CI/GM/1.0/RI	650±4	1720	2220	49	830	78	63	253	180	265	6	20	141.5	821.4	23600
500	9670/500/HCL100/CI/GM/1.0/RI	700±4	1990	2540	49	930	78	74	253	180	265	6	20	141.5	1049.5	29600
600	9670/600/HCL125/CI/GM/1.0/RI	800±4	2280	2930	49	1050	78	74	263	210	295	6	20	172.5	1544.5	43750
700	9670/700/HCL150/CI/GM/1.0/RI	1130±6	2500	3250	64	1100	97	74	270	251	350	6	24	204.0	2536.9	72800
750	9670/750/HCL200/CI/GM/1.0/RI	1200±6	2750	3550	69	1250	102	101	285	315	415	8	24	267.0	2883.4	82235
800	9670/800/HCL200/CI/GM/1.0/RI	1250±6	2900	3750	69	1350	102	101	285	315	415	8	24	267.0	3913.2	100000
900	9670/900/HCL200/CI/GM/1.0/RI	1380±6	3150	4100	79	1500	116	101	285	315	415	8	24	267.0	4487.1	125000
1000	9670/1000/HCL250/CI/GM/1.0/RI	1500±6	3420	4450	79	1650	116	113	295	380	480	10	24	332.0	5183.34	170000
1100	9670/1100/HCL250/CI/GM/1.0/RI	1650±7	3780	4900	89	1650	126	113	295	380	480	10	24	332.0	5748.34	220000

Rising Valve with Hydraulic Cylinder of PN 1.6 Rating

SUDE

9670

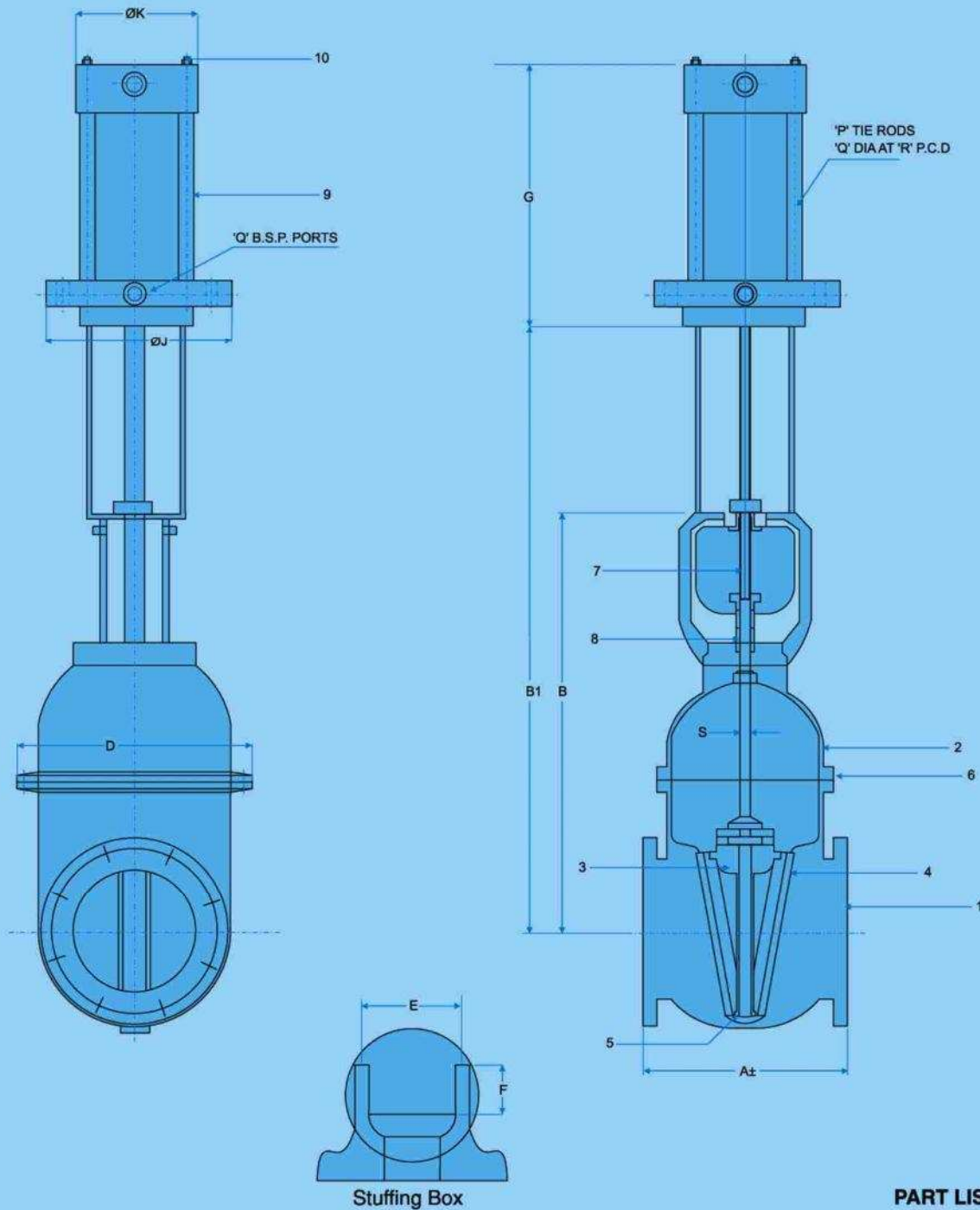

PART LIST

S.No.	DESCRIPTION
1	BODY
2	BONNET
3	WEDGE
4	BODY SEAT RISING
5	WEDGE FACE RING
6	BOLTS & NUTS
7	STEM
8	GLAND PACKING
9	HYDRAULIC CYLINDER
10	SCREW NUT

DIMENSIONS OF RISING VALVE PN 1.6 RATING

SIZE NB	ACTUATOR MODEL NUMBER	A±	Height (Approx)		Stem Dia. S	Width D	I.D. of stuffing box E	Depth of stuffing box F	G	K	J	P	Q	R	WT. OF ASSY IN KGS.	Cv
			B (C)	B1(O)												
300	9670/3 00/HCL 100/CI/GM/1.6/RI	380	1260	1570	42	610	76	68	253	180	265	6	20	141.5	364.5	9925
350	9670/350/HCL 100/CI/GM/1.6/RI	690±4	1390	1780	43	650	88	76	253	180	265	6	20	141.5	519.81	13800
400	9670/400/HCL 125/CI/GM/1.6/RI	750±4	1630	2070	49	750	78	88	263	210	295	6	20	172.5	782.5	18375
450	9670/450/HCL 125/CI/GM/1.6/RI	820±5	1770	2260	54	850	83	88	263	210	295	6	20	172.5	891.9	23600
500	9670/500/HCL 150/CI/GM/1.6/RI	820±5	1900	2430	54	900	83	88	270	251	350	6	24	204.0	1203.6	29600

Rising Valve with Electric Actuator of PN 0.4 Rating

SUDE

9650

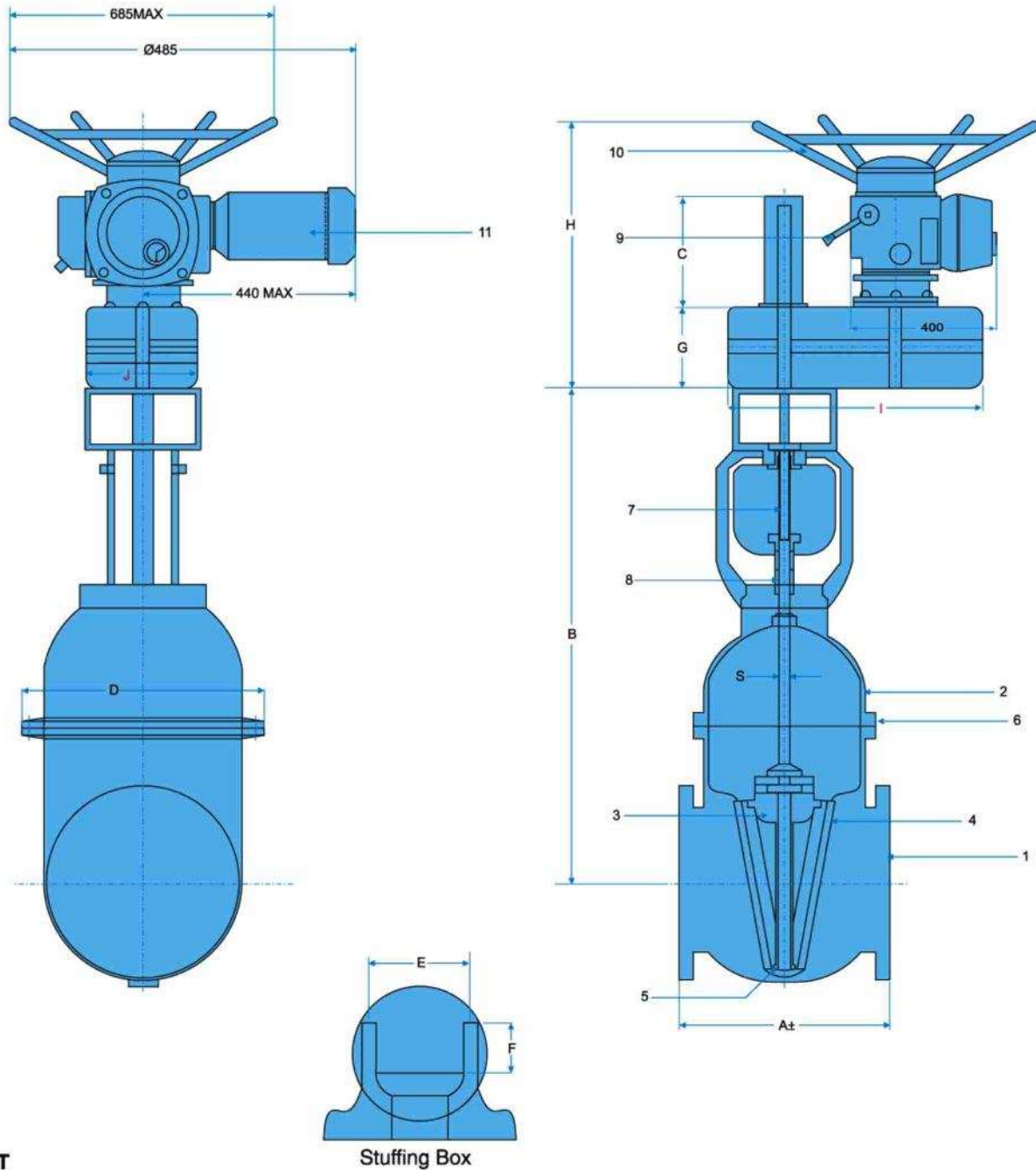

PART LIST

S.No.	DESCRIPTION
1	BODY
2	BONNET
3	WEDGE
4	BODY SEAT RISING
5	WEDGE FACE RING
6	BOLTS&NUTS
7	STEM
8	GLAND PACKING
9	CLUTCH LEVER
10	HAND WHEEL
11	ELECTRIC MOTOR

DIMENSIONS OF RISING VALVE PN - 0.4 RATING

SIZE NB	ACTUATOR MODEL NUMBER	At	Height (Approx)		Stem Dia.	Width	I.D. of stuffing box	Depth of stuffing box	G	H	I	J	Cv	WT. OF ASSY IN KGS.
			B	C										
700	9650/700/CI/GM/SD-3000-20-SG2.5-A/0.4/RI	635±4	2360	750	54	1050	83	59	142	670	500	258	72800	2504
750	9650/750/CI/GM/SD-3000-20-SG2.5-A/0.4/RI	685±4	2560	800	54	1200	83	59	142	670	500	258	82235	2730
800	9650/800/CI/GM/SD-3000-20-SG2.5-A/0.4/RI	700±4	2760	850	59	1250	92	67	142	670	500	258	100000	3750
900	9650/900/CI/GM/SD-3000-20-SG04-A/0.4/RI	740±4	3050	950	64	1350	97	67	142	670	530	258	125000	4334
1000	9650/1000/CI/GM/SD-3000-20-SG06-A/0.4/RI	760±4	3250	1050	69	1470	102	67	165	695	610	380	170000	4915
1100	9650/1100/CI/GM/SD-3000-20-SG08-A/0.4/RI	780±4	3340	1150	69	1550	102	67	165	695	604	380	220000	5490

Rising Valve with Electric Actuator of PN 0.6 Rating

SUDE

9650

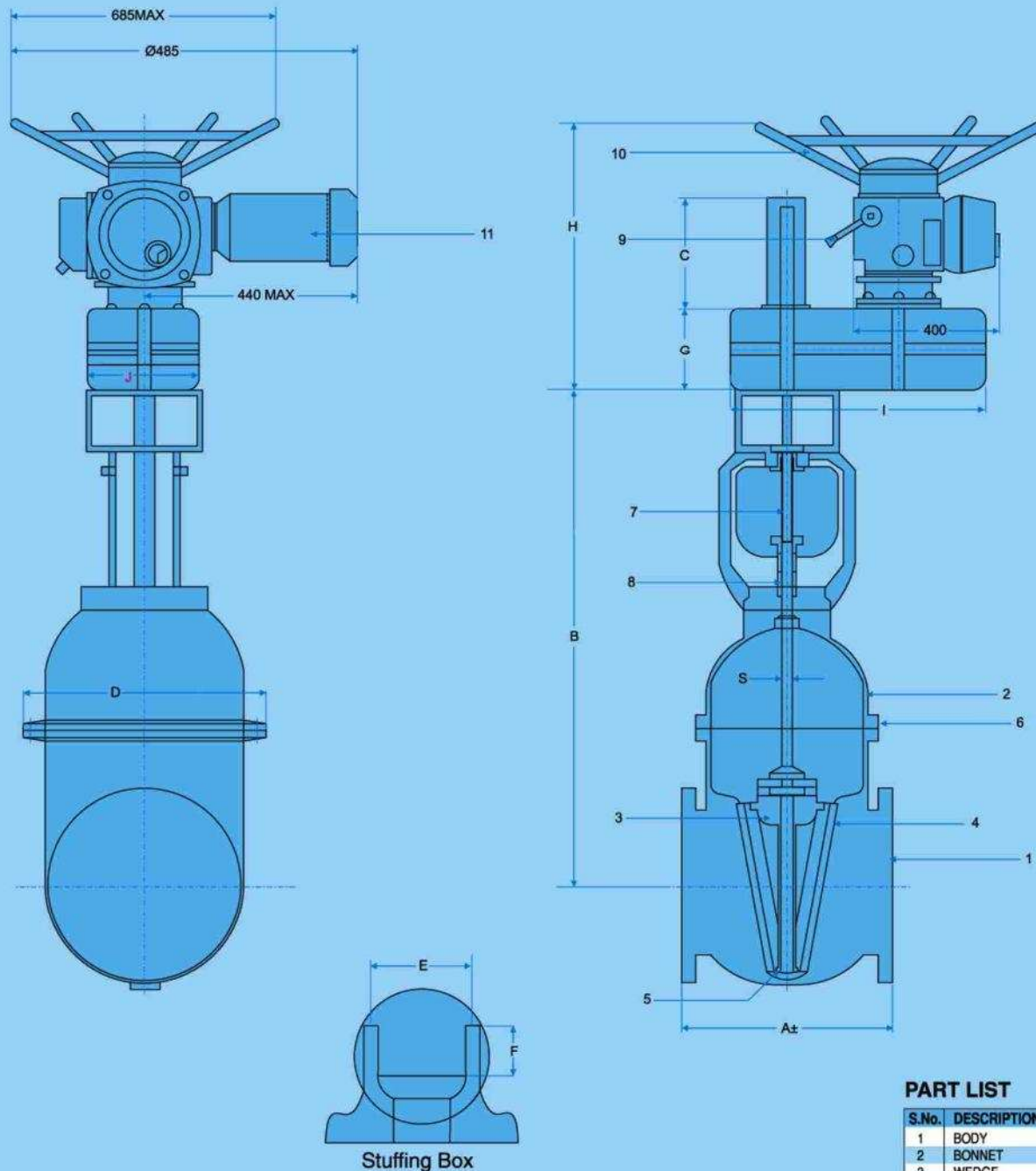

PART LIST

S.No.	DESCRIPTION
1	BODY
2	BONNET
3	WEDGE
4	BODY SEAT RISING
5	WEDGE FACE RING
6	BOLTS&NUTS
7	STEM
8	GLAND PACKING
9	CLUTCH LEVER
10	HAND WHEEL
11	ELECTRIC MOTOR

DIMENSIONS OF RISING VALVE PN - 0.6 RATING

SIZE NB	ACTUATOR MODEL NUMBER	A±	Height (Approx)		Stem Dia.	Width	I.D. of stuffing box	Depth of stuffing box	G	H	I	J	Cv	WT. OF ASSY IN KGS.
			B	C										
350	9650/350/CI/GM/SD-3000-20-SG2.5-A/0.6/RI	435±3	1360	400	39	650	64	51	142	670	500	258	13800	545
400	9650/400/CI/GM/SD-3000-20-SG2.5-A/0.6/RI	470±3	1510	450	43	700	68	51	142	670	500	258	18375	733
450	9650/450/CI/GM/SD-3000-20-SG2.5-A/0.6/RI	500±3	1690	500	43	750	68	51	142	670	500	258	23600	870
500	9650/500/CI/GM/SD-3000-20-SG04-A/0.6/RI	525±3	1820	600	49	830	78	59	142	670	530	258	29600	1117
600	9650/600/CI/GM/SD-3000-20-SG04-A/0.6/RI	555±3	2100	700	49	950	78	59	142	670	530	258	43750	1586
700	9650/700/CI/GM/SD-3000-20-SG04-A/0.6/RI	900±5	2550	750	54	1150	83	74	142	670	530	258	72800	2524
750	9650/750/CI/GM/SD-3000-20-SG04-A/0.6/RI	950±5	2650	800	54	1200	83	74	142	670	530	258	82235	2750
800	9650/800/CI/GM/SD-3000-20-SG04-A/0.6/RI	1000±5	2960	850	59	1380	90	84	142	670	530	258	100000	3770
900	9650/900/CI/GM/SD-3000-20-SG06-A/0.6/RI	1100±6	3200	950	64	1400	97	84	165	695	610	380	125000	4359
1000	9650/1000/CI/GM/SD-3000-20-SG08-A/0.6/RI	1200±6	3330	1050	69	1500	102	84	165	695	604	380	170000	4925
1100	9650/1100/CI/GM/SD-3000-20-SG12-A/0.6/RI	1300±6	3660	1150	79	1600	116	95	200	615	720	490	220000	5525

Rising Valve with Electric Actuator of PN 1.0 Rating

SUDE

9650

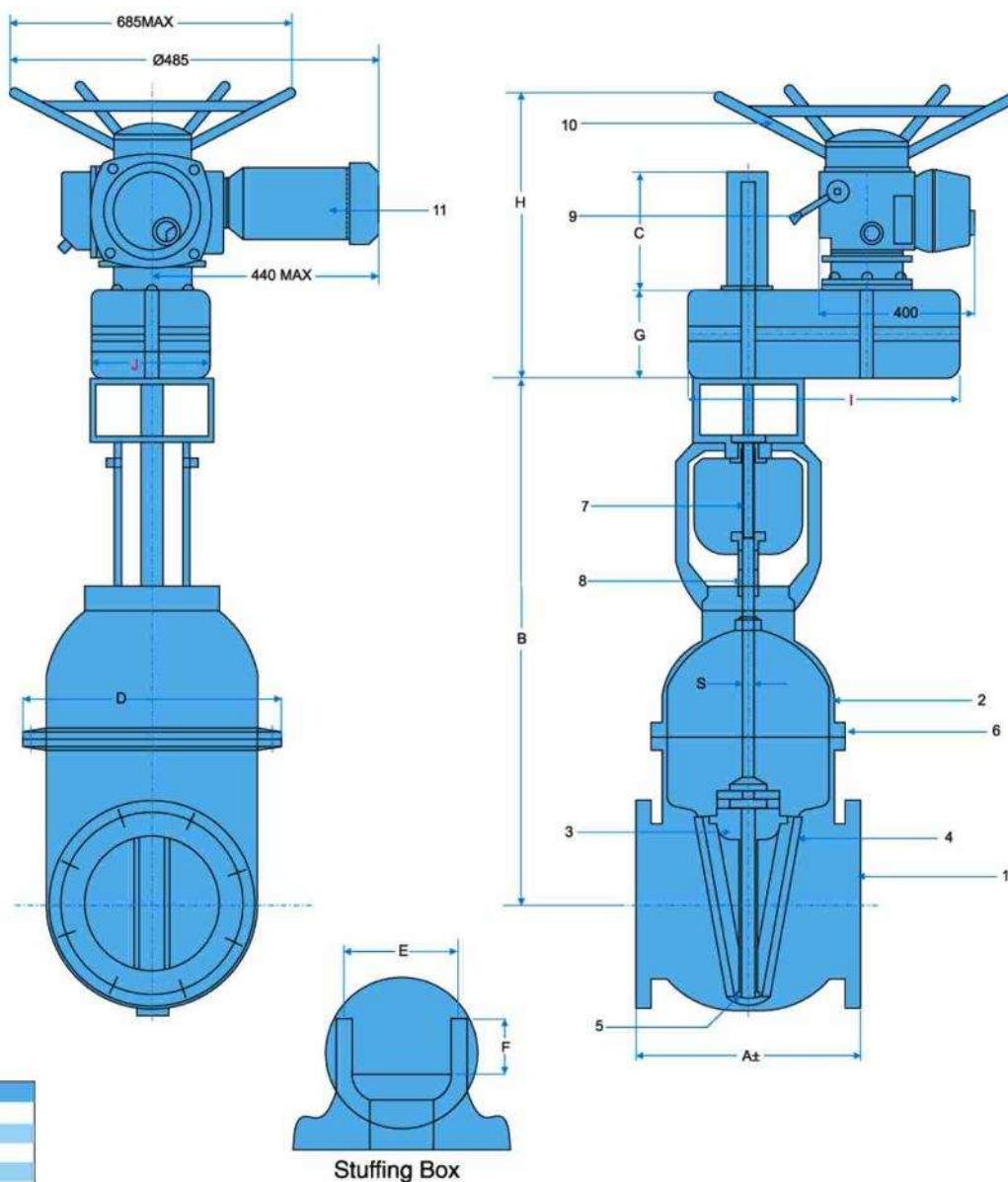

PART LIST

S.No.	DESCRIPTION
1	BODY
2	BONNET
3	WEDGE
4	BODY SEAT RISING
5	WEDGE FACE RING
6	BOLTS&NUTS
7	STEM
8	GLAND PACKING
9	CLUTCH LEVER
10	HAND WHEEL
11	ELECTRIC MOTOR

DIMENSIONS OF RISING VALVE PN 1.0 RATING

SIZE NB	ACTUATOR MODEL NUMBER	A±	Height (Approx)		Stem Dia.	Width	I.D. of stuffing box	Depth of stuffing box	G	H	I	J	Cv	WT. OF ASSY IN KGS.
			B	C										
50	9650/50/CI/GM/SD-3000-08-A/1.0/RI	215	435	100	24	160	44	42	142	482	500	258	300	83
65	9650/65/CI/GM/SD-3000-08-A/1.0/RI	230	510	110	24	200	44	42	142	482	500	258	335	87
80	9650/80/CI/GM/SD-3000-08-A/1.0/RI	230	615	130	24	220	44	42	142	482	500	258	510	94
100	9650/100/CI/GM/SD-3000-08-A/1.0/RI	255	620	150	28	250	48	42	142	482	500	258	945	109
125	9650/125/CI/GM/SD-3000-20-A/1.0/RI	266	650	175	28	300	48	42	142	592	500	258	1525	142
150	9650/150/CI/GM/SD-3000-20-A/1.0/RI	280	720	200	28	330	52	42	142	592	500	258	2250	158
200	9650/200/CI/GM/SD-3000-20-A/1.0/RI	318	870	250	32	460	56	51	142	592	500	258	4150	203
250	9650/250/CI/GM/SD-3000-20-A/1.0/RI	355	1115	300	36	495	60	51	142	592	500	258	6700	270
300	9650/300/CI/GM/SD-3000-20-SG2.5-A/1.0/RI	380	1260	350	36	585	60	51	142	670	500	258	9925	398
350	9650/350/CI/GM/SD-3000-20-SG2.5-A/1.0/RI	550±3	1480	400	39	730	64	51	142	670	500	258	13800	535
400	9650/400/CI/GM/SD-3000-20-SG2.5-A/1.0/RI	600±3	1680	450	43	800	68	63	142	670	500	258	18375	773
450	9650/450/CI/GM/SD-3000-20-SG04-A/1.0/RI	650±4	1720	500	49	830	78	63	142	670	530	258	23600	890
500	9650/500/CI/GM/SD-3000-20-SG04-A/1.0/RI	700±4	1990	550	49	930	78	74	142	670	530	258	29600	1117
600	9650/600/CI/GM/SD-3000-20-SG06-A/1.0/RI	800±4	2280	650	49	1050	78	74	165	695	530	380	43750	1611
700	9650/700/CI/GM/SD-3000-20-SG06-A/1.0/RI	1130±6	2500	750	64	1100	97	74	165	695	530	380	72800	2549
750	9650/750/CI/GM/SD-3000-20-SG06-A/1.0/RI	1200±6	2750	800	69	1250	102	101	165	695	530	380	82235	2775
800	9650/800/CI/GM/SD-3000-20-SG06-A/1.0/RI	1250±6	2900	850	69	1350	102	101	165	695	530	380	100000	3795
900	9650/900/CI/GM/SD-3000-20-SG12-A/1.0/RI	1380±6	3150	950	79	1500	116	101	200	615	720	490	125000	4404
1000	9650/1000/CI/GM/SD-3000-20-SG12-A/1.0/RI	1500±6	3420	1050	79	1650	116	113	200	615	720	490	170000	4960
1100	9650/1100/CI/GM/SD-3000-20-SG12-A/1.0/RI	1650±7	3780	1150	89	1650	126	113	200	615	720	490	220000	5525

Rising Valve with Electric Actuator of PN 1.6 Rating

SUDE

9650

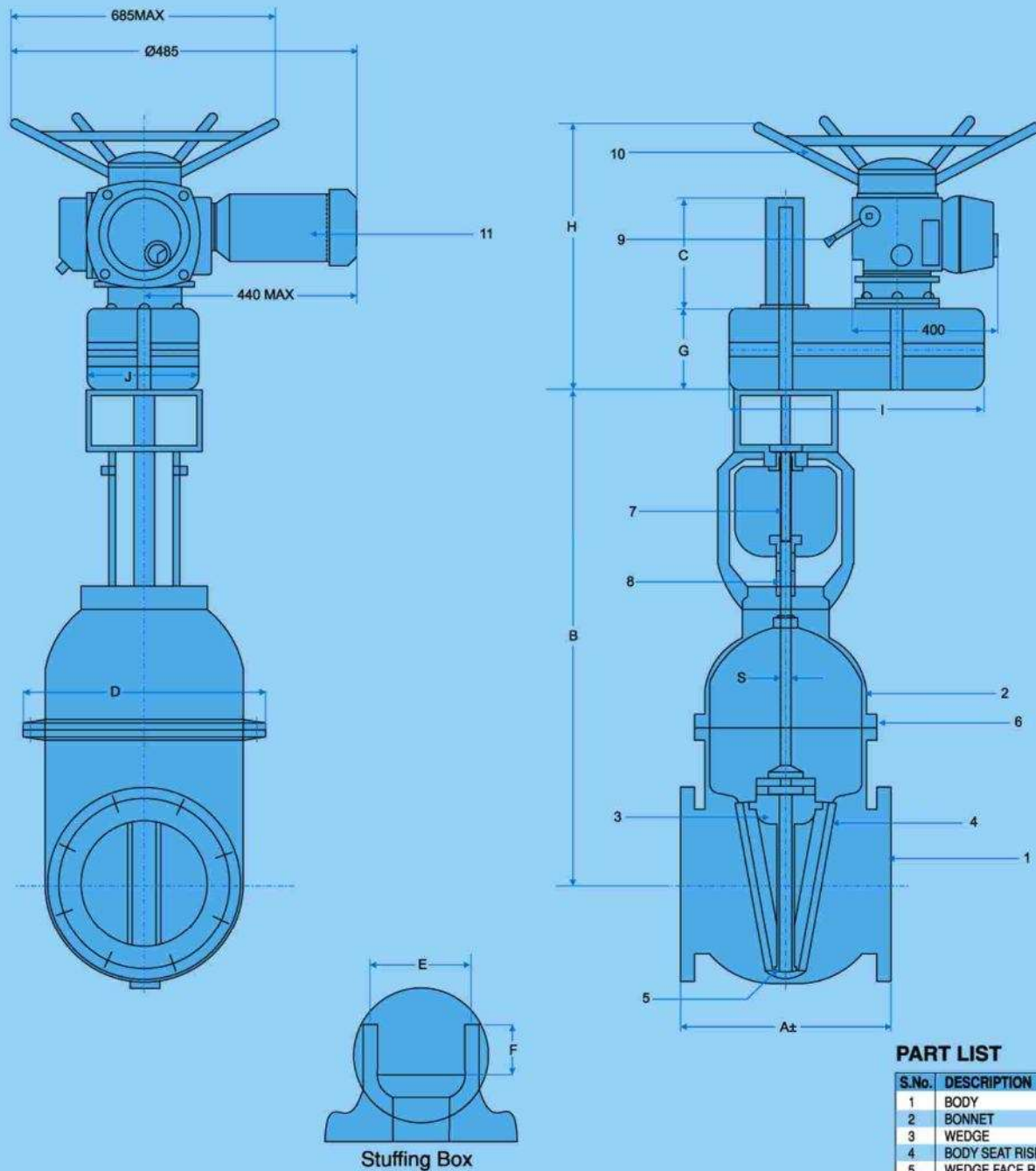

PART LIST

S.No.	DESCRIPTION
1	BODY
2	BONNET
3	WEDGE
4	BODY SEAT RISING
5	WEDGE FACE RING
6	BOLTS&NUTS
7	STEM
8	GLAND PACKING
9	CLUTCH LEVER
10	HAND WHEEL
11	ELECTRIC MOTOR

DIMENSIONS OF RISING VALVE PN - 1.6 RATING

SIZE NB	ACTUATOR MODEL NUMBER	A±	Height (Approx)		Stem Dia.	Width	I.D. of stuffing box	Depth of stuffing box	G	H	I	J	Cv	WT. OF ASSY IN KGS.
			B	C										
50	9650/50/CI/GM/SD-3000-08-A/1.6/RI	215	435	100	26	190	50	53	142	482	500	258	300	83
65	9650/65/CI/GM/SD-3000-08-A/1.6/RI	230	510	110	26	225	50	53	142	482	500	258	335	87
80	9650/80/CI/GM/SD-3000-08-A/1.6/RI	230	615	130	26	250	50	53	142	482	500	258	510	94
100	9650/100/CI/GM/SD-3000-08-A/1.6/RI	255	620	150	30	290	54	53	142	482	500	258	945	109
125	9650/125/CI/GM/SD-3000-20-A/1.6/RI	266	650	175	30	325	54	53	142	592	500	258	1525	142
150	9650/150/CI/GM/SD-3000-20-A/1.6/RI	280	720	200	32	350	56	53	142	592	500	258	2250	158
200	9650/200/CI/GM/SD-3000-20-A/1.6/RI	318	870	250	38	480	70	68	142	592	500	258	4150	203
250	9650/250/CI/GM/SD-3000-20-SG2.5-A/1.6/RI	355	1115	300	44	525	76	68	142	670	500	258	6700	340
300	9650/300/CI/GM/SD-3000-20-SG2.5-A/1.6/RI	380	1260	350	42	610	76	68	142	670	500	258	9925	408
350	9650/350/CI/GM/SD-3000-20-SG04-A/1.6/RI	690±4	1390	400	43	650	68	76	142	670	530	258	13800	565
400	9650/400/CI/GM/SD-3000-20-SG06-A/1.6/RI	750±4	1630	450	49	750	78	88	165	695	610	380	18375	828
450	9650/450/CI/GM/SD-3000-20-SG06-A/1.6/RI	820±5	1770	500	54	850	83	88	165	695	610	380	23600	915
500	9650/500/CI/GM/SD-3000-20-SG08-A/1.6/RI	820±5	1900	550	54	900	83	88	165	695	604	380	29600	1152

Non Rising Valve with Electric Actuator of PN 0.4 Rating

SUDE

9660

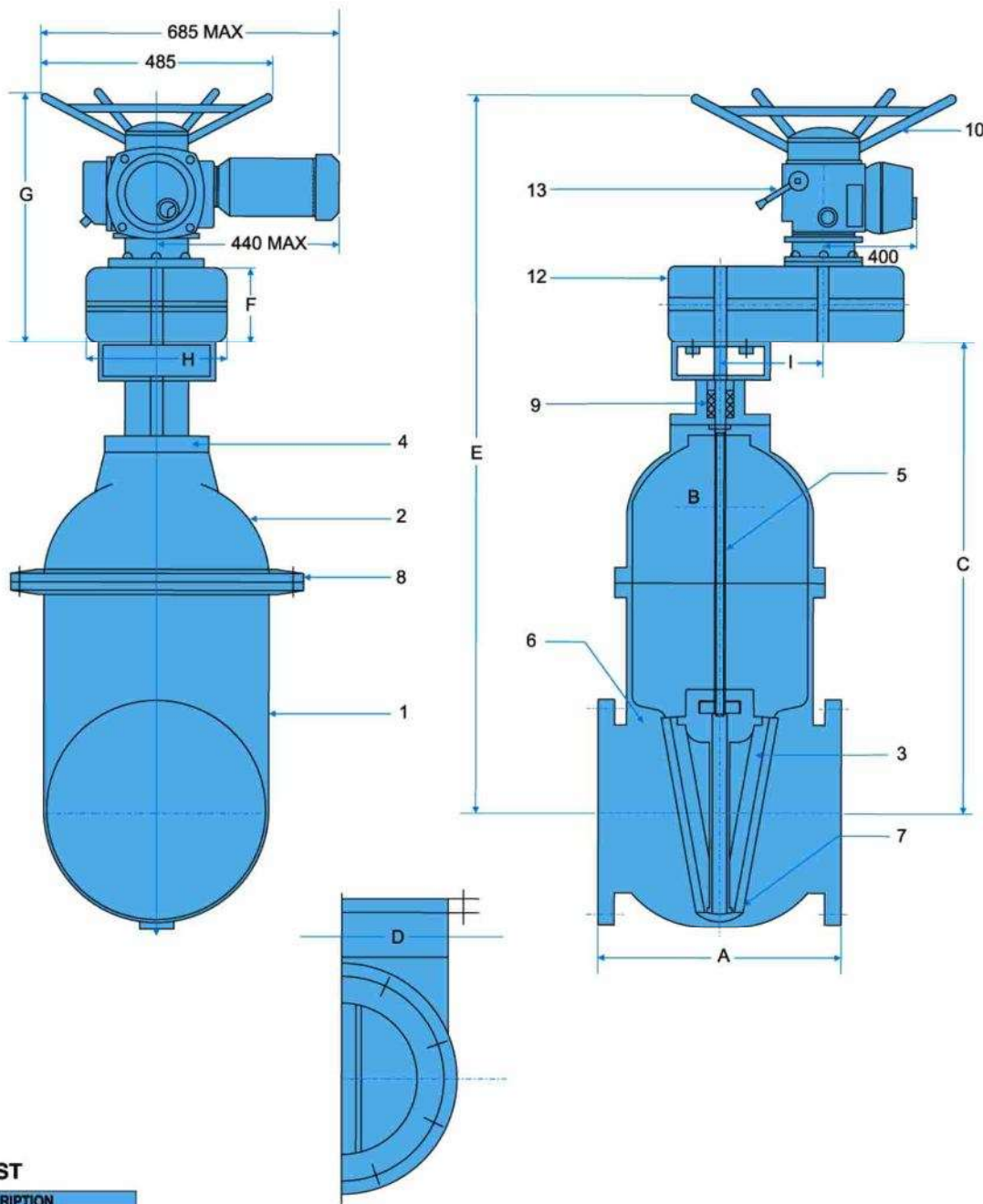

PART LIST

S.No.	DESCRIPTION
1	BODY
2	BONNET
3	WEDGE
4	GLAND
5	STEM
6	BODY SEAT RISING
7	WEDGE FACE RING
8	WEDGE NUT
9	GLAND PACKING
10	HAND WHEEL
11	ELECTRIC MOTOR
12	GEAR BOX
13	CLUTCH LEVER

DIMENSIONS OF NON - RISING VALVE PN - 0.4 RATING

SIZE NB	ACTUATOR MODEL NUMBER	A±2	B	C	D	E	Dia of Spindle Screw	Sq. of Spindle	Depth of Nut (Min)	I.D. of Stuffing Box	Depth of Stuffing Box	Length of Spindle	Cv	F	G	H	I	WT. OF ASSY IN KGS.
			Stem Dia	Height (Approx)	Width (Max)													
700	9650/700/CI/GM/SD-3000-08-SG2.5-E/0.4/NR	635±4	54	1650	1050	2320	55	41	55	83	59	74	72800	142	670	258	180	2504
750	9650/750/CI/GM/SD-3000-08-SG04-E/0.4/NR	685±4	54	1760	1200	2455	55	41	55	83	59	74	82235	142	670	258	210	2750
800	9650/800/CI/GM/SD-3000-08-SG06-E/0.4/NR	700±4	59	1850	1250	2545	60	41	60	92	67	74	100000	165	695	380	190	3795
900	9650/900/CI/GM/SD-3000-08-SG06-E/0.4/NR	740±4	64	2100	1350	2795	65	46	65	97	67	80	125000	165	695	380	190	4359
1000	9650/1000/CI/GM/SD-3000-08-SG08-E/0.4/NR	760±4	69	2250	1470	2945	70	50	70	102	67	88	170000	165	695	380	190	4915
1100	9650/1100/CI/GM/SD-3000-08-SG08-E/0.4/NR	780±4	69	2350	1550	3045	70	50	70	102	67	88	220000	165	695	380	183	5490

Non Rising Valve with Electric Actuator of PN 0.6 Rating

SUDE

9660

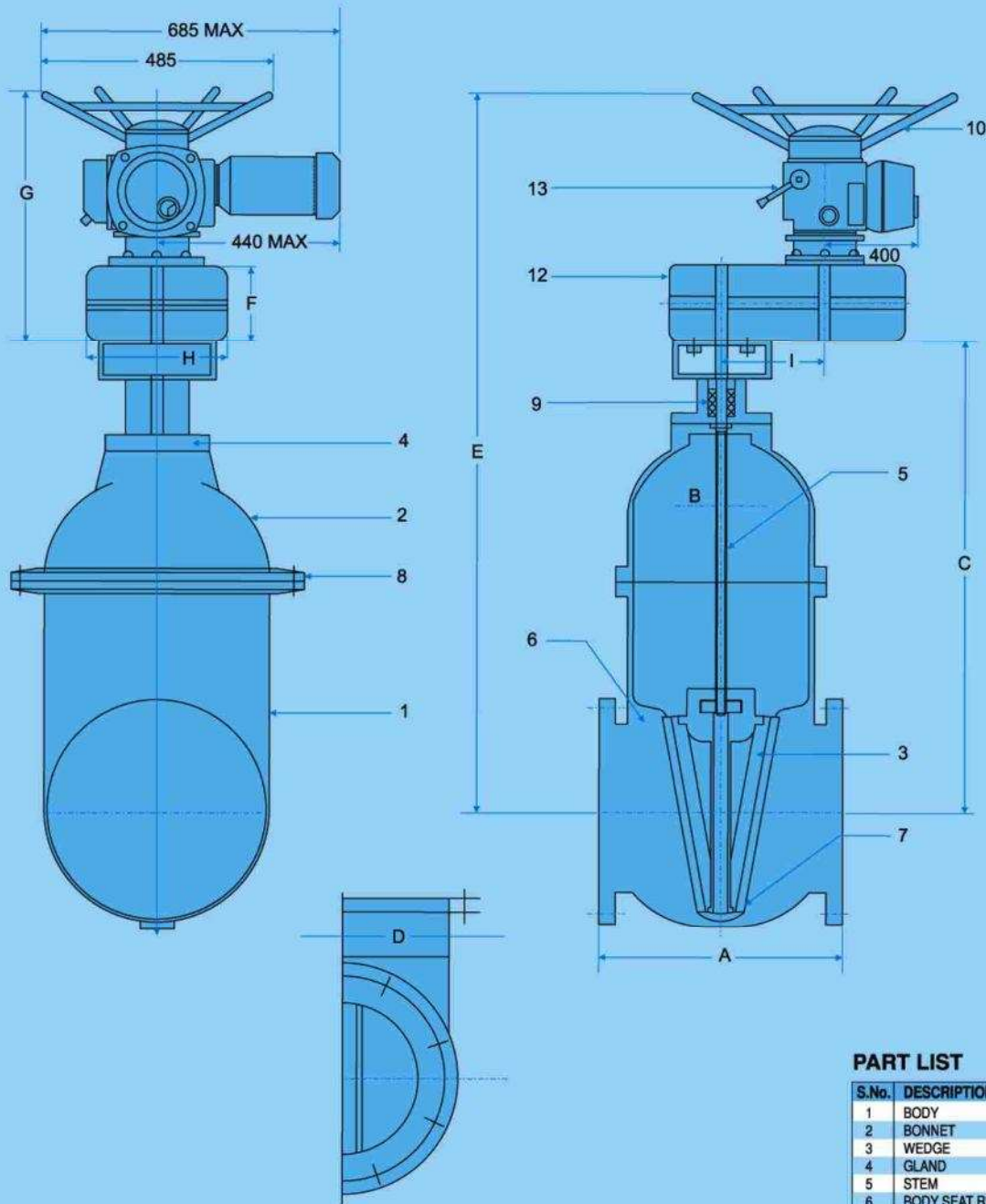

PART LIST

S.No.	DESCRIPTION
1	BODY
2	BONNET
3	WEDGE
4	GLAND
5	STEM
6	BODY SEAT RISING
7	WEDGE FACE RING
8	WEDGE NUT
9	GLAND PACKING
10	HAND WHEEL
11	ELECTRIC MOTOR
12	GEAR BOX
13	CLUTCH LEVER

DIMENSIONS OF NON - RISING VALVE PN - 0.6 RATING

SIZE NB	ACTUATOR MODEL NUMBER	A±2	B			E	Dia of Spindle Screw	Sq. of Spindle	Depth of Nut (Min)	I.D. of Stuffing Box	Depth of Stuffing Box	Length of Spindle	F	G	H	I	Cv	WT. OF ASSY IN KGS.
			Stem Dia	Height (Approx)	Width (Max)													
350	9650/350/CI/GM/SD-3000-20-SG2.5-E/0.6/NR	435±3	39	1020	650	1690	40	27	40	64	51	47	142	670	258	180	13800	545
400	9650/400/CI/GM/SD-3000-20-SG2.5-E/0.6/NR	470±3	43	1110	700	1780	44	32	44	68	51	55	142	670	258	180	18375	783
450	9650/450/CI/GM/SD-3000-20-SG2.5-E/0.6/NR	500±3	43	1210	750	1880	44	32	44	68	51	55	142	670	258	180	23600	870
500	9650/500/CI/GM/SD-3000-20-SG04-E/0.6/NR	525±3	49	1300	830	1970	50	36	50	78	59	66	142	670	258	210	29600	1117
600	9650/600/CI/GM/SD-3000-20-SG04-E/0.6/NR	555±3	49	1500	950	2170	50	36	50	78	59	66	142	670	258	210	43750	1586
700	9650/700/CI/GM/SD-3000-20-SG04-E/0.6/NR	900±5	54	1670	1150	2340	55	41	55	83	74	74	142	670	258	210	72800	2524
750	9650/750/CI/GM/SD-3000-20-SG04-E/0.6/NR	950±5	54	1780	1200	2450	55	41	55	83	74	74	142	670	258	210	82235	2750
800	9650/800/CI/GM/SD-3000-20-SG06-E/0.6/NR	1000±5	59	1930	1380	2625	60	41	60	90	84	74	165	695	380	190	100000	3795
900	9650/900/CI/GM/SD-3000-20-SG08-E/0.6/NR	1100±6	64	2080	1400	2775	65	46	65	97	84	80	165	695	380	183	125000	4369
1000	9650/1000/CI/GM/SD-3000-20-SG08-E/0.6/NR	1200±6	69	2180	1500	2875	70	50	70	102	84	88	165	695	380	183	170000	4925
1100	9650/1100/CI/GM/SD-3000-20-SG12-E/0.6/NR	1300±6	79	2400	1600	3015	80	55	110	116	95	90	200	615	490	240	220000	5225

Non Rising Valve with Electric Actuator of PN 1.0 Rating

SUDE

9660

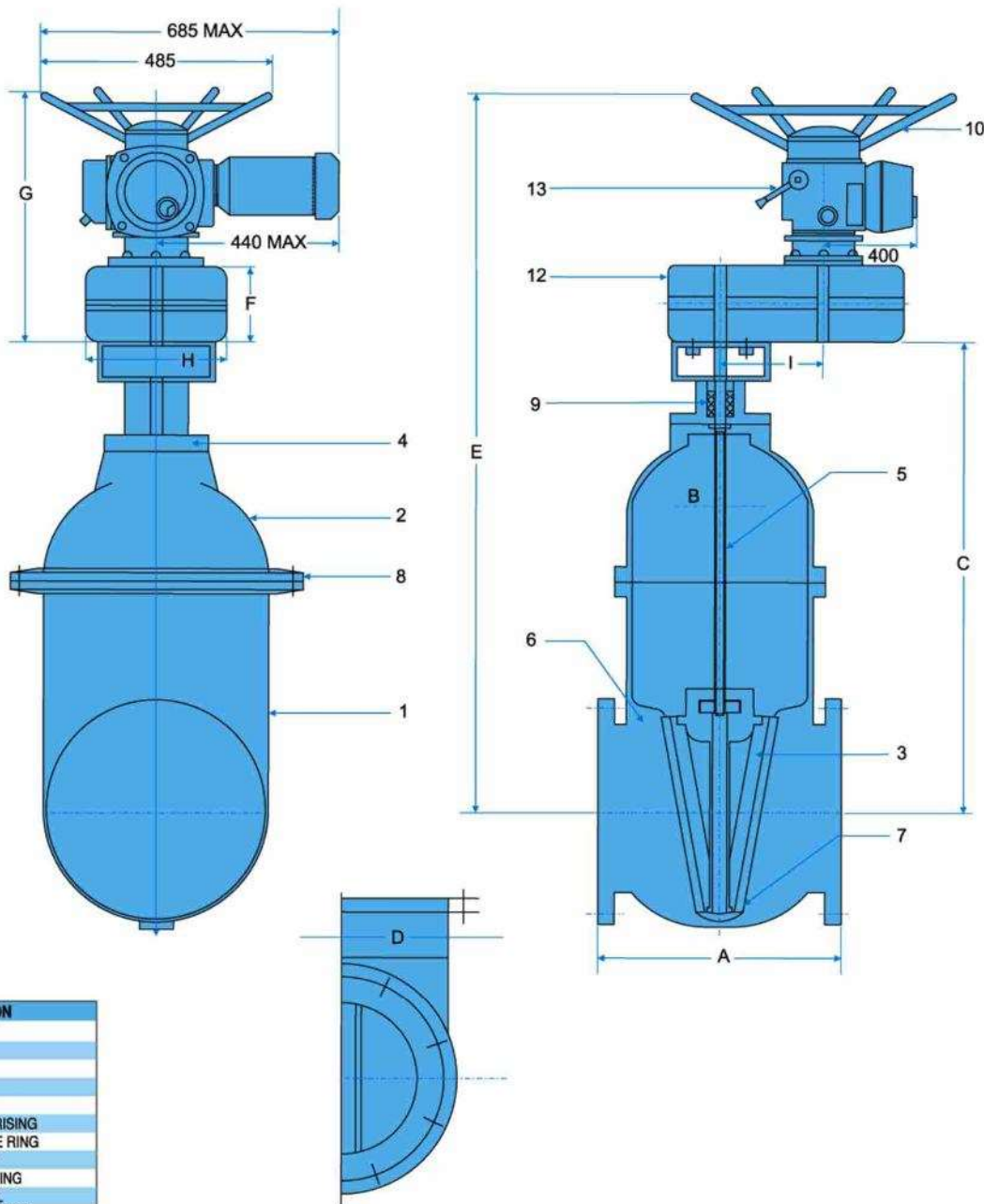

PART LIST

S.No.	DESCRIPTION
1	BODY
2	BONNET
3	WEDGE
4	GLAND
5	STEM
6	BODY SEAT RISING
7	WEDGE FACE RING
8	WEDGE NUT
9	GLAND PACKING
10	HAND WHEEL
11	ELECTRIC MOTOR
12	GEAR BOX
13	CLUTCH LEVER

DIMENSIONS OF NON - RISING VALVE PN - 1.0 RATING

SIZE NB	ACTUATOR MODEL NUMBER	A±2	B	C	D	E	Depth of Nut (Min)	LD. of Stuffing Box	Depth of Stuffing Box	F	G	H	I	Cv	WT. OF ASSY IN KGS.
			Stem Dia	Height (Approx)	Width (Max)										
50	9650/50/CI/GM/SD-3000-08-E/1.0/NR	215	24	365	160	847	30	44	42	142	482	258	180	300	83
65	9650/65/CI/GM/SD-3000-08-E/1.0/NR	230	24	390	200	872	30	44	42	142	482	258	180	335	87
80	9650/80/CI/GM/SD-3000-08-E/1.0/NR	230	24	425	220	907	30	44	42	142	482	258	180	510	94
100	9650/100/CI/GM/SD-3000-08-E/1.0/NR	255	28	470	250	952	35	48	42	142	482	258	180	945	109
125	9650/125/CI/GM/SD-3000-08-E/1.0/NR	266	28	540	300	1022	35	48	42	142	482	258	180	1525	132
150	9650/150/CI/GM/SD-3000-20-E/1.0/NR	280	28	595	330	1187	35	52	51	142	592	258	180	2250	158
200	9650/200/CI/GM/SD-3000-20-E/1.0/NR	318	32	725	460	1317	42	56	51	142	592	258	180	4150	203
250	9650/250/CI/GM/SD-3000-20-SG2.5-E/1.0/NR	355	36	835	495	1505	48	60	51	142	670	258	180	6700	340
300	9650/300/CI/GM/SD-3000-20-SG2.5-E/1.0/NR	380	36	910	585	1580	48	60	51	142	670	258	180	9925	408
350	9650/350/CI/GM/SD-3000-20-SG2.5-E/1.0/NR	550±3	39	1030	730	1700	40	64	63	142	670	258	180	13800	545
400	9650/400/CI/GM/SD-3000-20-SG04-E/1.0/NR	600±3	43	1100	800	1770	44	68	63	142	670	258	210	18375	803
450	9650/450/CI/GM/SD-3000-20-SG06-E/1.0/NR	650±3	49	1200	830	1895	50	78	74	165	695	380	190	23600	915
500	9650/450/CI/GM/SD-3000-20-SG06-E/1.0/NR	700±3	49	1340	930	2035	50	78	74	165	695	380	190	29600	1142
600	9650/450/CI/GM/SD-3000-20-SG06-E/1.0/NR	800±3	49	1500	1050	2195	50	78	74	165	695	380	190	43750	1611
700	9650/450/CI/GM/SD-3000-20-SG06-E/1.0/NR	1130±5	64	1620	1100	2315	65	97	101	165	695	380	190	72800	2547
750	9650/750/CI/GM/SD-3000-20-SG08-E/1.0/NR	1200±5	69	1720	1150	2415	70	102	101	165	695	380	183	82235	2785
800	9650/800/CI/GM/SD-3000-20-SG08-E/1.0/NR	1250±5	69	1820	1250	2515	70	102	101	165	695	380	183	100000	3805
900	9650/900/CI/GM/SD-3000-20-SG12-E/1.0/NR	1380±6	79	2040	1350	2655	110	116	113	200	615	490	240	125000	4404
1000	9650/1000/CI/GM/SD-3000-20-SG12-E/1.0/NR	1500±6	79	2200	1500	2815	110	116	113	200	615	490	240	170000	4960
1100	9650/1100/CI/GM/SD-3000-20-SG12-E/1.0/NR	1650±6	89	2400	1650	3015	125	125	113	200	615	490	240	220000	5525

Non Rising Valve with Electric Actuator of PN 1.6 Rating

SUDE

9660

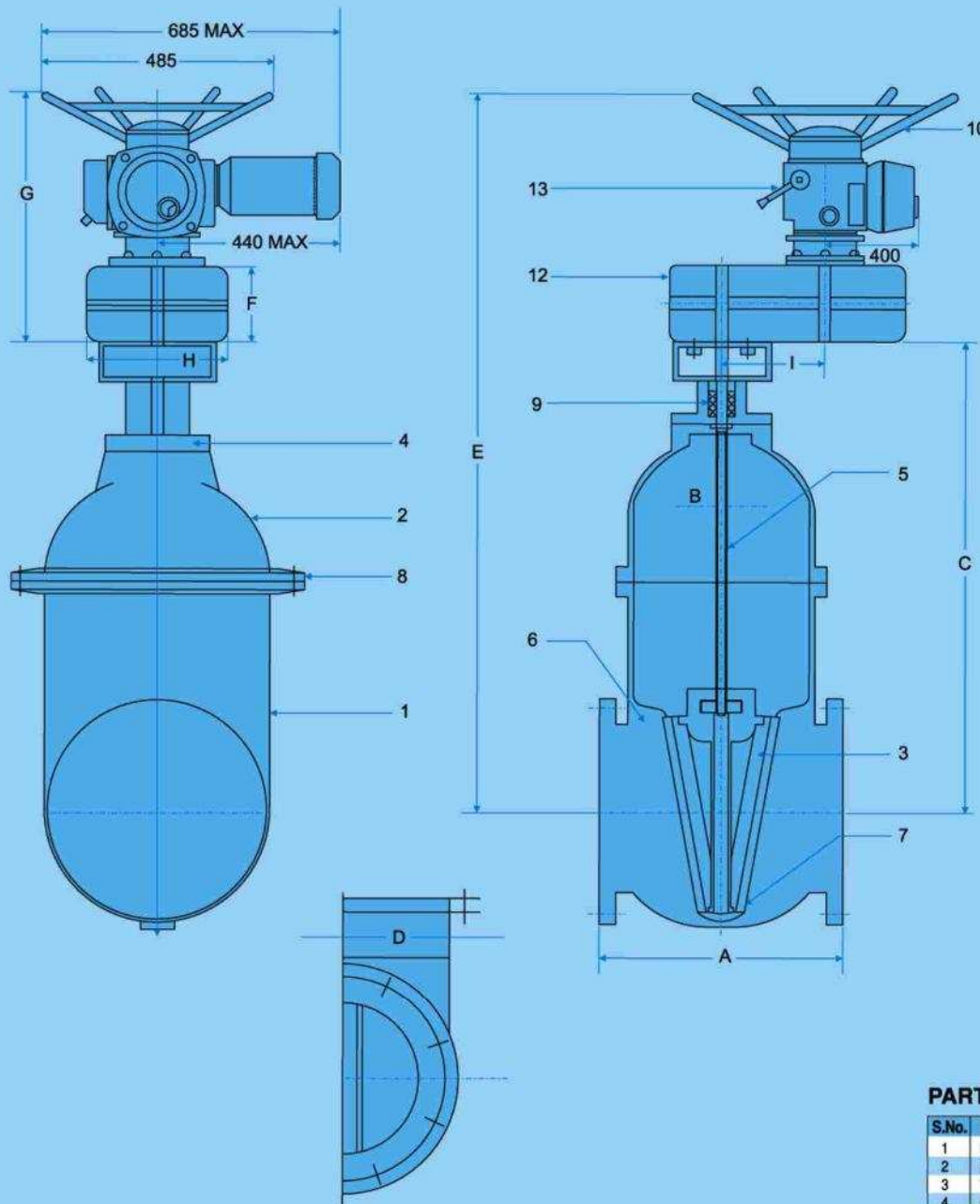

PART LIST

S.No.	DESCRIPTION
1	BODY
2	BONNET
3	WEDGE
4	GLAND
5	STEM
6	BODY SEAT RISING
7	WEDGE FACE RING
8	WEDGE NUT
9	GLAND PACKING
10	HAND WHEEL
11	ELECTRIC MOTOR
12	GEAR BOX
13	CLUTCH LEVER

DIMENSIONS OF NON - RISING VALVE PN - 1.6 RATING

SIZE NB	ACTUATOR MODEL NUMBER	A±2	B	C	D	E	Depth of Nut (Min)	I.D. of Stuffing Box	Depth of Stuffing Box	F	G	H	I	Cv	WT. OF ASSY IN KGS.
			Stem Dia	Height (Approx)	Width (Max)										
50	9650/50/CI/GM/SD-3000-08-E	215	26	390	190	872	30	44	42	142	482	258	180	300	83
65	9650/65/CI/GM/SD-3000-08-E	230	26	420	225	902	30	44	42	142	482	258	180	335	87
80	9650/80/CI/GM/SD-3000-08-E	230	26	460	220	942	30	44	42	142	482	258	180	510	94
100	9650/100/CI/GM/SD-3000-08-E	255	30	520	250	1002	35	48	42	142	482	258	180	945	109
125	9650/125/CI/GM/SD-3000-20-E	266	30	575	300	1167	35	48	42	142	592	258	180	1525	142
150	9650/150/CI/GM/SD-3000-20-E	280	32	625	330	1217	35	52	51	142	592	258	180	2250	158
200	9650/200/CI/GM/SD-3000-20-E	318	38	765	460	1357	42	56	51	142	592	258	180	4150	203
250	9650/250/CI/GM/SD-3000-20-SG2.5-E	355	44	875	495	1545	48	60	51	142	670	258	180	6700	340
300	9650/300/CI/GM/SD-3000-20-SG2.5-E	380	44	965	585	1635	48	60	51	142	670	258	180	9925	408
350	9650/350/CI/GM/SD-3000-20-SG04-E	690±3	43	940	650	1610	44	68	76	142	670	258	210	13800	565
400	9650/400/CI/GM/SD-3000-20-SG06-E	750±3	49	1070	750	1765	50	78	88	165	695	380	190	18375	828
450	9650/450/CI/GM/SD-3000-20-SG08-E	820±3	54	1170	850	1865	55	83	88	165	695	380	183	23600	925
500	9650/500/CI/GM/SD-3000-20-SG08-E	880±3	54	1260	900	1875	55	83	88	200	615	490	240	29600	1152



OUR OTHER PRODUCTS:

- Solenoid Valves.
- Pneumatically operated Control Valves.
- Motorised Valves.
- Pneumatic & Electric Operated Ball / Butterfly valves.
- Pneumatic & Motorised Dampers.
- Pneumatic & Motorised VIV Dampers.
- Heavy duty – Single phase & Three phase actuators for operating Gates & chutes.
- motorised Rising & Non-rising Sluice valve.
- Pneumatic & Motorised Pinch Valve.
- Pneumatic & Motorised Flush Bottom valve.
- Pneumatic & Motorised Dampers.
- Entire range of Electrical Actuator.
- And Instrumentation Product likes Pressure Transmitter, PID Controller, Flow meter etc., for System Integration.

NOTE : TECHNICAL SPECIFICATIONS, DETAILS & DIMENSIONS ARE SUBJECT TO CHANGE WITHOUT PRIOR NOTICE. DIMENSIONS IN THE TABLE ARE APPROXIMATE SUBJECT TO FINAL CONFIRMATION BY SUDE.



Head Office, Bangalore

SUDE ENGINEERING CORPORATION

Registered Office / Works :

Shop No. 1106, 10th Main Road, R.P.C. Layout,
Near R.P.C. Layout Bus Stop, Hampinagar,
Bangalore 560 104. (Old Pin 560040) Karnataka, India

Tel. : +91 80 2330 2145 / 2314 1104 / 2340 2297

Fax : +91 80 2330 5729

Cell : +91 9845018216

Pune Office / Works :

Gat No. 94/2, Plot No.1, Alandi Markal Road,
Village - Dhanore, Tal - Khed, Pune 412105.
Maharashtra, India

Tel. : +91 9763719689, 9763719690

Cell : +91 9822980003, 9845018216



SUDE

An ISO 9001:2008 Certified Company