

DAMPER 1900SERIES

- Square Rectangular Damper
- Variable Inlet Vane Damper
- High Temperature Damper
- Diverter Damper
- Poppet Damper
- Stack Damper
- Fire Damper
- Guillotine Damper
- High Temperature Slide Gate



YES. WE CARE...
| Courteously | Attentively | Respectably | Effectively |

SUDE[®]
An ISO 9001:2008 Certified Company

Damper

Index

Introduction	01
Purpose of Damper	02
Selection Guide	02
Damper Selection Guide	03
Type of Dampers & its Leakage Class	07
Seat Selection Guideline	07
Sealing Efficiency For Dampers	08
Standard Construction Features of Butterfly Damper	09
Standard Construction Features of Square / Rectangular Damper	11
Variable Inlet Vane Damper	16
Typical test Bench for Dampers Efficiency Check	19
High Temperature Damper	20
Diverter Damper	21
Poppet Dampers	23
Stack Dampers	25
Fire Damper	27
Guillotine Damper	29
High Temperature Slide Gate	32
Comparison Features and General Comments	33
GA Drawings.....	36
Conventional System	45
Test & Inspection.....	45

Introduction

For over 20 years, Sude has been the leader in designing and manufacturing durable, high performance dampers for industrial and other types of ventilation applications.

Sude's goal is to deliver products that meet and exceed industry standards. Experienced, professional engineers, and development, and the latest in manufacturing technology are the key ingredients that assure superiority of Sude products.

With a history of developing original ideas, Sude is known for its innovation and use of leading-edge technology. This includes using the latest materials to custom build dampers and louvers to withstand the most stringent environments.

When it comes to industrial ventilation, contractors and engineering firms depend on Sude to provide the industry's finest product. From light operations to heavy-duty applications, we build dampers that meet the most demanding situations. Every damper is built with performance in mind and is designed to meet the highest specification.

Since most industrial systems cannot be shut down for normal periodic maintenance, our products are designed to support options such as exposed linkages and outboard bearing packages. These facilitate easy maintenance while the system is operational.

Sude works with a variety of materials, including galvanized steel, aluminum, stainless steel etc. in order to match our customer's exact specifications. By molding and forming these materials, we can develop dampers to fit almost any application.

The company has the technology and experience to design and manufacture multi-blade airfoil damper. A welded frame combined with thick axles and outboard bearings provide the damper with both structural integrity and performance. Perfect for applications requiring low levels of leakage at high static pressures.

Sude design provides many benefits:

- Lower pressure losses
- Low operating torque
- Operating torque not affected by airflow direction through damper
- Minimizes pressure losses through smaller dampers



Purpose of Damper

Major Purpose

- Control Air & Gas Flow
- Shut-Off Air & Gas Flow
- Changing Flow Direction



High Temperature
Abrasive Dusty
Low Cost Effect



Sub Purpose

- Control Duct Pressure
- Control Duct Temperature
- Emergency Exhaust

Selection Guide

MATERIAL
Thermal Consideration
Corrosion & Erosion
System Pressure
Connection To Duct

SUDE
An ISO 9001:2000 Certified Company

DESIGN EFFECT
Pressure Drop
Thermal Compensation
Margin Of Safety
Testing & Simulation

OPERATION
Pneumatic Operation
Electric Operation
Hydraulic Operation
Manual & Others

sdtork
The Complete Solution in Valve Automation

SEALING
Flat Bar Or Plate Seal
Flexible Seal
Seal Air Method
Others

Damper Actuator Selection Criteria

The Actuator assembly for Damper the most important point is the Torque and Positioning accuracy which plays the major role for smooth operation

Torque:

The torque that is required to operate a damper depends upon the size, type, quality & condition of the damper. It is also dependent upon the differential pressure & air flow. Contrary to popular belief; the maximum required torque is not always at the closed position. Typically, the maximum torque requirement is found at about 30% open position. Refer figure 12.

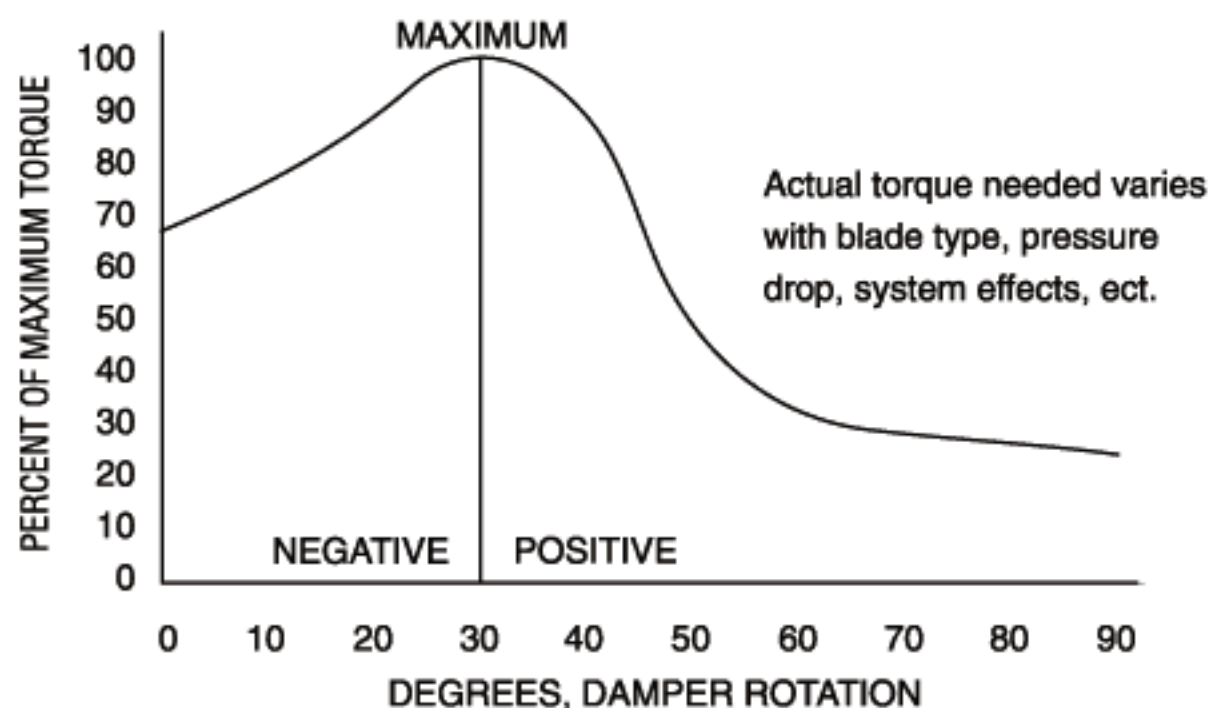

Figure 12 : Typical Torque Requirement.

Linkage:

The actuator is connected to the damper via a linkage, which has a couple of ball joints, pivots & other elements that have some play. The slack in the linkage can easily cause a 1 – 3% hysteresis, when the stress changes from a pulling force to a pushing force. This effect requires the actuator to move about 1- 3% before the damper begins to move. The amount of hysteresis depends upon the condition of the linkage & how well it has been adjusted. If the linkage is improperly adjusted & the joints are worn, the hysteresis can actually be larger than 5%.

Damper Positioning Accuracy

	Pneumatic Without positioner	Pneumatic With positioner	Electronic With linkage	Direct Coupled
Actuator	12%	2 ½ - 5%	1%	1%
Linkage	1 – 3%	1 – 3%	1 – 3%	None
E/P Transducer	2%	2%	None	None
Total	15 – 17%	5 ½ - 10%	2 – 4%	1%

As it can be seen from the above table, direct coupled electronic actuators are more accurate than any other type of actuator.

When selecting an actuator, the following criteria should be taken into careful consideration

Should the actuator be Manual, Electric or Pneumatic ?

Manual :

Locking quadrant actuators can be used if the damper's position is fixed (when used for balancing airflow) or needs to change only occasionally (such as summer/winter changeover).

Electric :

Easier interface with digital control devices. Electric actuators must have a voltage selected. Typical actuator voltages are 24vac, 110vac, 240 vac and 415 volts. Fail safe electric actuators are also called spring return, and the fail position (open or closed) should be noted. For detail on the Electric actuator refer Sdtork, Pune and asked for detailed literature. The spring return Electrical actuator are available for low torque for higher values we suggest you to use reversible stay put type actuator.

ACCESSORIES:

- Position limit switches [1 NO + 1 NC or 2NO+2NC] change over type
- Travel limit switches [1 NO + 1 NC]
- Hand wheel
- Local position indication

OPTIONAL ACCESSORIES, CONTROL & PROTECTIONS:

- Extra limit switches
- 2 NO + 2NC contacts for travel limit switches
- 2 NO + 2NC contacts for torque limit switches
- 'H' class insulation for motor
- Side mounted hand wheels to reduce rim pull effort, geared hand wheel is provided
- Remote position indicator Potentiometer, Current position transmitter, Non-contact type position transmitter
- Remote position indicator Analog / Digital
- Power supply
- Push button station
- Blinker switch
- Integral starter
- Control panel
- Electronic positioner
- Single phase protection
- Special control / protection features as per application demands can also be given for specific requirements.

Pneumatic :

Pneumatic actuators are available in rotary construction in Double and spring return in on/off and modulating duty format. Actuators will be inherently fail safe, but fail position (open or closed) should be noted. Pneumatic actuators are supplied with Electro pneumatic positioners which works on continuous pressurized air of 60psi and input signal of 4 to 20mA with a feed back of 4 to 20mA. For details refer actuator catalogue.

Accessories:

- For Double Acting Actuator – 4 way 5 port single coil / Double coil solenoid valve in General purpose or Flame proof and explosion coils.
- For Spring Return Actuator – 3 way Single Coil.

ACCESSORY COMMON FOR DOUBLE ACTING / SPRING RETURN ACTUATOR:

- Pressure Regulator
- Limit Switches
- Filter Regulator with Lubricator
- Gear Box with hand wheel for manual operation
- Valve Positioner for characteristic controlled application.
- I to P Converter.
- Electro pneumatic positioners
- Position Indicator
- Position Transmitter
- Cyclic Timer or Sequential Timer
- 3 way / 4 way Key operated valves
- Stimulator
- Travel Stops
- Closing Limiter
- Silencers with flow control valve

OPTIONAL COMMON FOR BOTH PNEUMATIC AND ELECTRICAL ACTUATOR

- PID Controller along with PT – 100 Sensor supplied with panel.
- Pressure Transmitter supplied with panel.

What type of control action will the damper perform?

Balancing:

If the damper maintains a set position to balance airflow in a system, a manual locking quadrant is the appropriate actuator.

Two Position:

Opens the damper to allow airflow and/or close the damper to prevent airflow.

Modulating Control:

The position of the damper is determined by a modulating control signal from a device or controller that monitors temperature, pressure, or some other condition system. Actuators must be compatible with the control signal generated by the controller to which they are expected to respond. Electric actuator modulating control signals may be:

- 0 – 10 volts DC
- 4 – 20 milliamps DC
- 135 ohm

Pneumatic actuators respond to varying control air pressures and are selected with appropriate spring ranges to position dampers from open to closed (or closed to open) against 3 - 15 psi. Larger dampers and applications where precise damper positioning is critical should have pneumatic actuators equipped with positive positioners (3-15 psi signal) for added reliability.

Fail Safe:

Opens or closes the damper when power is removed from the actuator. Also called “normally open”, or “normally closed”, this actuator may be either two-position or modulating.

Mounting Position:

Externally or internally mounted.

Damper Performance Testing Criteria

Pressure loss through an open damper (change in pressure) and leakage through a closed damper are two performance criteria required to appropriately select and apply a control damper in any system.

Periodic Louver & Damper Inspection & Maintenance

All adjustable louvers and automatic dampers should be checked and serviced on a regular schedule. Inspection intervals depend on system usage and atmospheric conditions within the system.

Basic Inspection

- All louvers and dampers should be checked for freedom of movement. Shafts, bearings, pivot points, etc. should be cleaned and lubricated with a light spray oil.
- Blades should be checked in the closed position to insure tight closure. Adjustments should be made at linkage to correct any misalignment.
- Motors (electric or pneumatic) should be visually checked through their complete cycle for defects, binding or misalignment. Operator anchorage and fittings should also be checked.
- Blades should be checked for freedom of movement. Blades should be disconnected from their operators and manually checked. (Blades should move freely with no binding or twisting).
- Pins, straps and bushings should be checked for wear, corrosion or rust. Replace or paint as required.
- Check louver or damper blade edge and Jamb seals (where applicable)
- Check all linkage, connecting bars and operator connections for proper alignment and fit.
- Check overall installation to insure that louver or damper was installed in a perfectly plumb and square position and proper clearance was allowed for blade, linkage and operator movement.

Note: Dampers with non-metallic or carbon sleeve bearings do not require lubrication.

Most of the difficulties experienced on older damper installations may be traced to:

1. Misalignment of frame, blades, shafts, or interconnecting linkage.
2. Racking or distortion of frames.
3. Insufficient drive motor power or pilot positioning pneumatic relay incorrectly set.
4. Inadequate sealing.
5. Inadequate cleaning and lubrication.
6. Excessive wear or grooving of linkage pivots.
7. Longer daily running time.
8. Lack of periodic inspection and maintenance.







Type of Dampers & its Leakage Class

SUDE

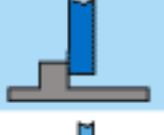
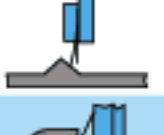
Damper	Feature		Remarks
Butterfly Damper	Normal Function	On - Off	Centric Eccentric Tandem, Togle
	Leakage Rate	Max 2% Under	
	No. of Blade	Single	
Louver Damper	Normal Function	On - Off	Single, Double Tandem Parallel, Opposed
	Leakage Rate	Max 3% Under	
	No. of Blade	Multiple	
Guillotine Damper	Normal Function	On - Off	For Isolation
	Leakage Rate	Max 1% Under	
	No. of Blade	Single	
Diverter Damper	Normal Function	On - Off	For Isolation
	Leakage Rate	Max 1% Under	
	No. of Blade	Single	
Stack Damper	Normal Function	On - Off Control	Simple Drive Composite Drive
	Leakage Rate	Max 1% Under	
	No. of Blade	Multiple	
Flap Damper	Normal Function	On - Off Control	Compact Apply Seal Air
	Leakage Rate	Max 2% Under	
	No. of Blade	Single, Double	

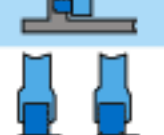
Seat Selection Guideline

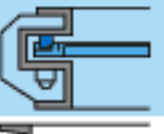
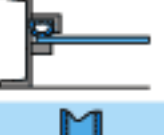
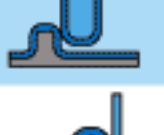
SUDE

Type	Damper	Seat	Efficiency	Press (mm/Aq)	Temp. (°C)	Application					Example
						Clean Air	Flue Gas	Abrasive Dusty	Waste Dusty	Corrosive Gas	
A	Butterfly Louver		98.5%	2,000	560	✓	✓	✓	✓		Cement Plant Power Plant
B	Butterfly Louver		98.5%	2,000	560	✓	✓	✓	✓		Air Supply System (HVAC)
C	Butterfly Louver		99.7%	2,000	560	✓	✓		✓	✓	Power Plant Incinerator
D	Butterfly Louver		*100%	2,000	560	✓	✓		✓	✓	Power Plant Incinerator
E	Butterfly Louver		99.8%	2,000	560	✓	✓	✓	✓	✓	De-Sox & De-Nox Incinerator
F	Butterfly Louver		99.5%	2,000	560	✓	✓	✓	✓	✓	De-Sox & De-Nox
G	Butterfly Louver		*100%	2,000	560		✓		✓	✓	De-Sox & De-Nox Chemical Plant
H	Diverter		*100%	2,000	350		✓		✓	✓	De-Sox & De-Nox Power Plant
I	Diverter		*100%	2,000	560	✓	✓	✓	✓	✓	Power Plant (HRSG)
J	Slide Gate Guillotine		99.5%	2,000	350		✓	✓			Power Plant
K	Sealing Rim Guillotine		*100%	2,000	650		✓	✓	✓	✓	De-Sox & De-Nox Chemical Plant
L	Buterfly Louver		98.0%	2,000	100	✓	✓	✓	✓	✓	Petro Chemical Plant
M	Butterfly Louver		99.5%	2,000	560	✓	✓	✓		✓	Power Plant

* Seal Air Required Condition

Sude designed various types of Sealing Arrangement to Achieve 97% to 99.8% Sealing Efficiency

Sealing for Stub End Side

Stuffing box with Bolted Gland & Gland Packing

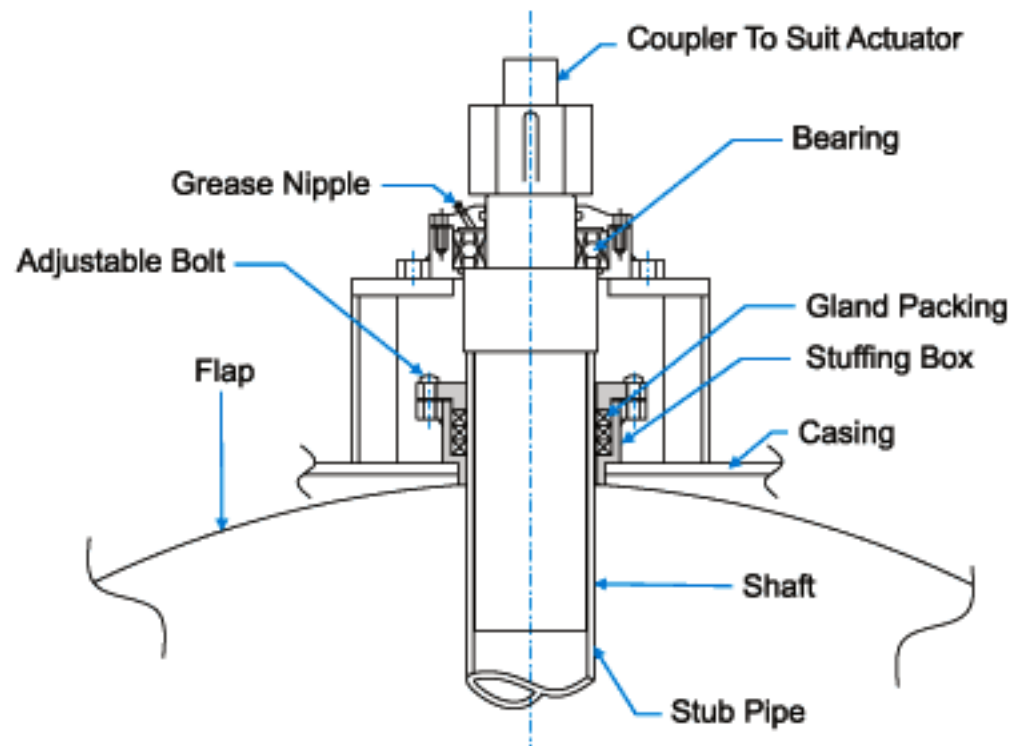

Stuffing box with Pre Tension Spring and Gland Packing

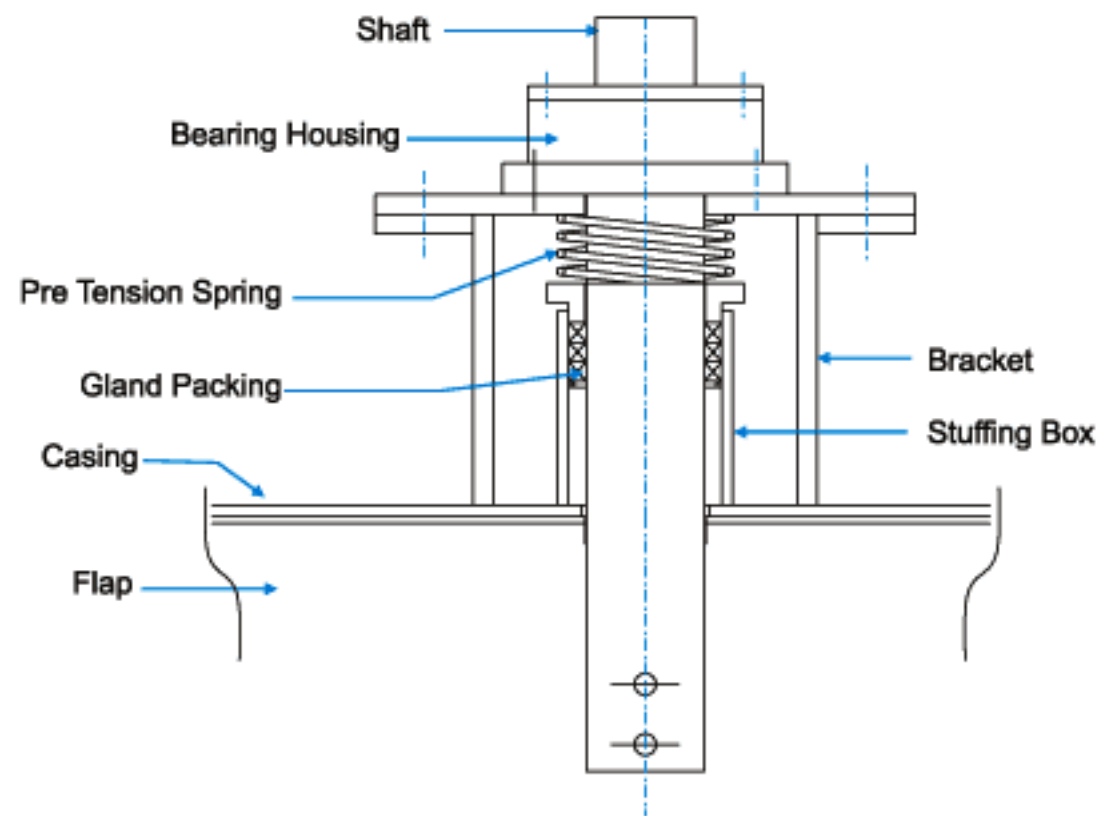

Sealing for Flap & Housing

Type B

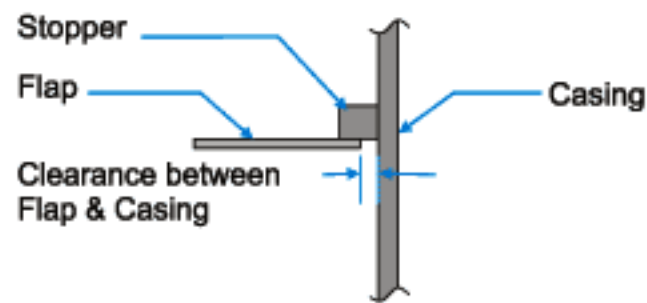

Type C

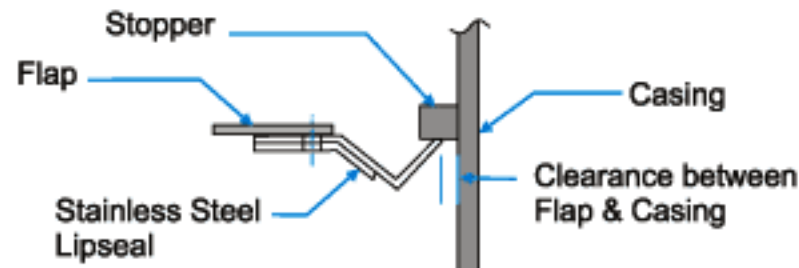

Type F

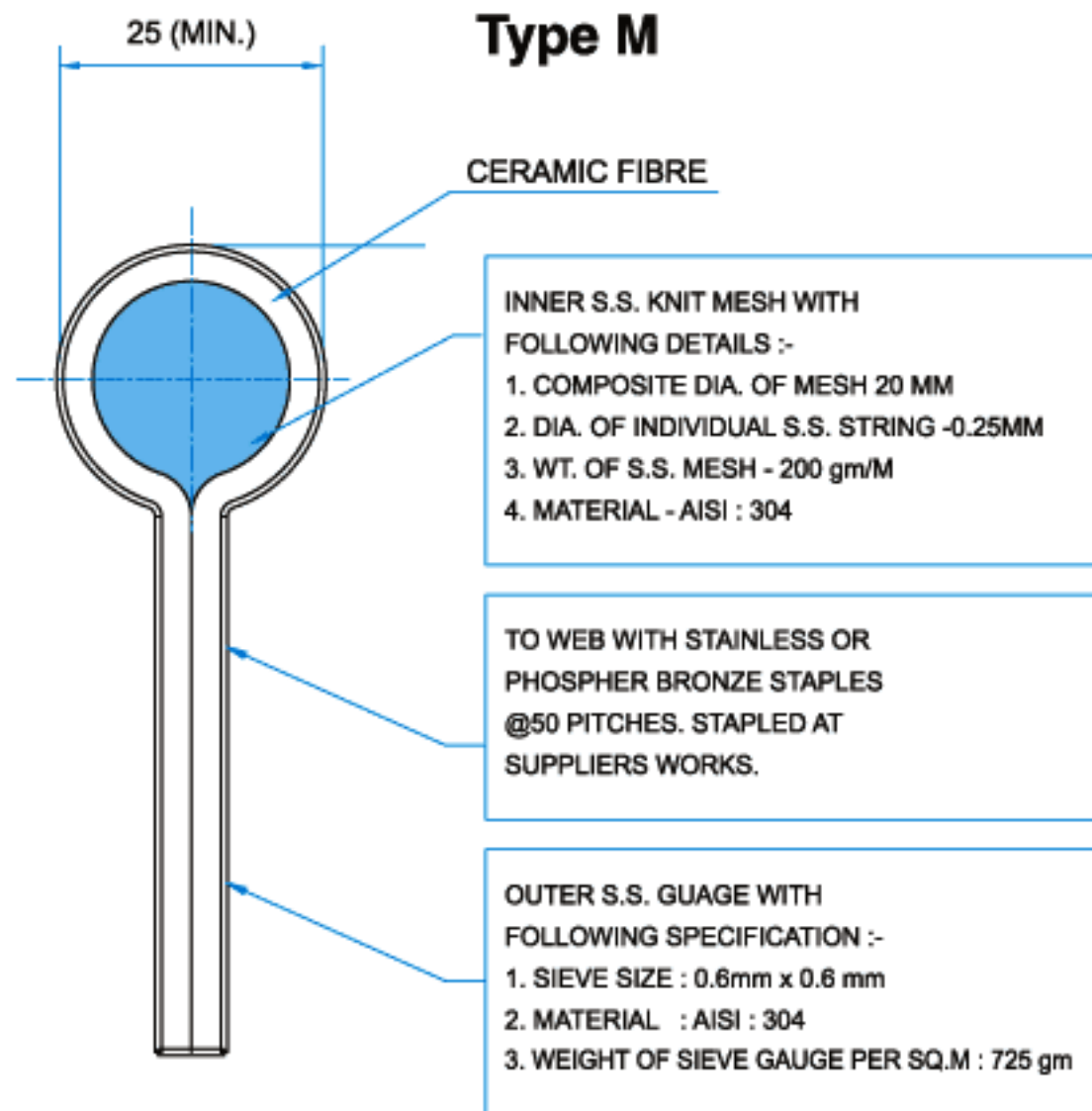
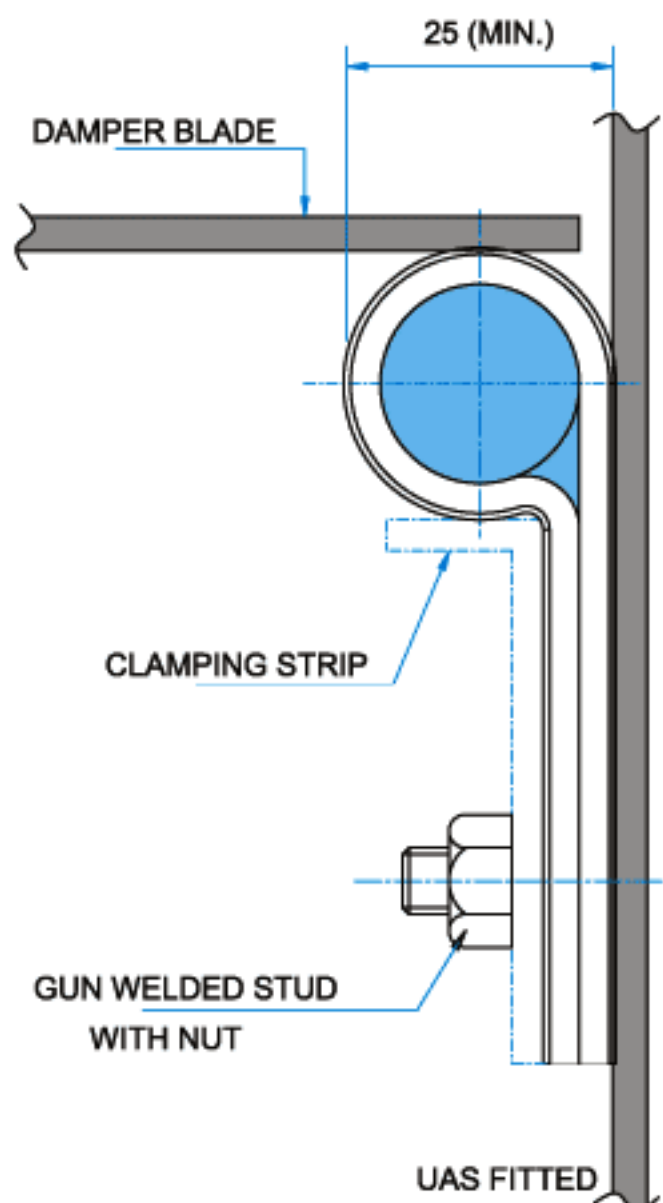
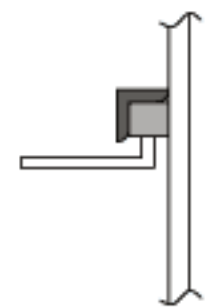

Sizes:

Any sizes can be made since they are fabricated.

Frame:

Mild steel body confirms to IS2062, and Boiler grade steel confirms to IS2002 with continuous welded flanges and alternatively Stainless steel, aluminum or any other weld able material. Structural channel is available for larger size dampers.

Vanes:

Single thick plate offset and formed at shaft for extra strength, reinforcing ribs are provided as required for intended service. The vane is welded to a continuous thru shaft alternatively Stainless, corrosion and abrasion resistant materials.

Shafts:

Shaft ends are marked to indicate vane position and it is made up of stainless steel continuous or stub shafts.

Bearings:

Ball/Bush bearings mounted outboard on stand-offs, over adjustable packing glands.

Glands:

Adjustable plate & follower design with fiberglass rope packing and alternatively Ceramic rope packing or any other commercially available packing material.

Seals:

No internal vane seals provided. Swing clearance between vanes and frame for approximately 98% shut-off when fully closed.

Paint:

Damper is hand cleaned and painted one shop coat of our standard industrial primer, or we also do the painting as per customer's specification.

Operator:

Extended operator shaft is provided for operating it with Pneumatic or Electrical actuators based on customer's requirements. Wide range of manual, electric, and pneumatic operators with options for modulating, fail safe, switches, etc available and they are assembled based on customers specification.

Link Assembly

Damper can be supply with various types of Coupling Arrangement as per application requirement as indicated bellow.

Coupling Arrangement for Actuator Mounting

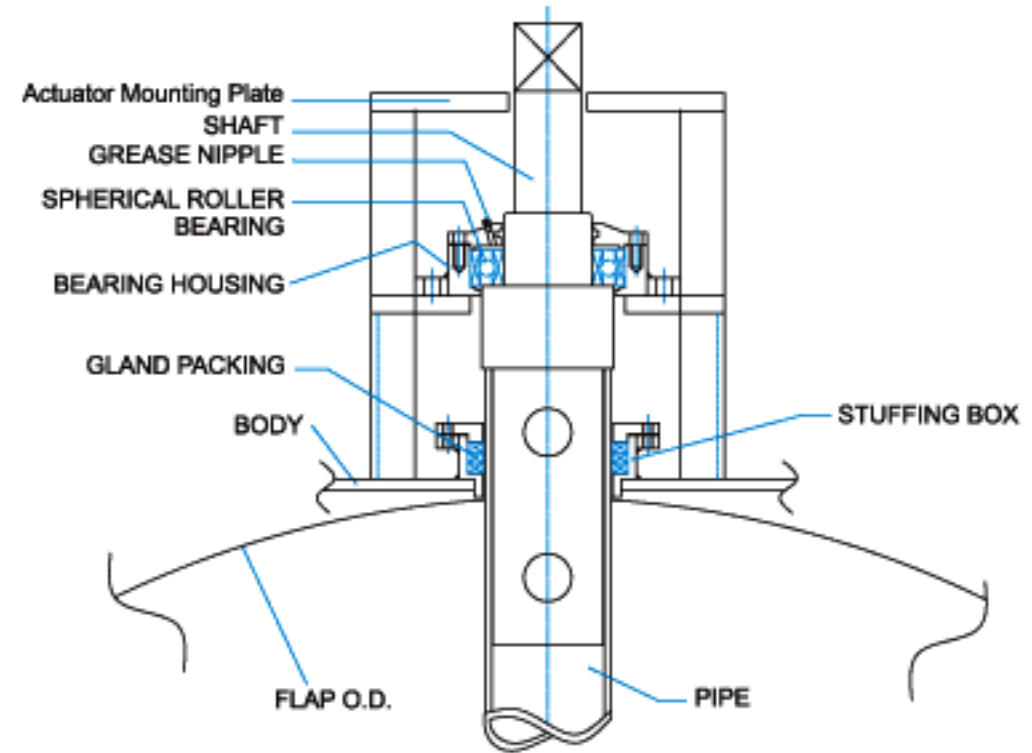

Direct Mounting Arrangement

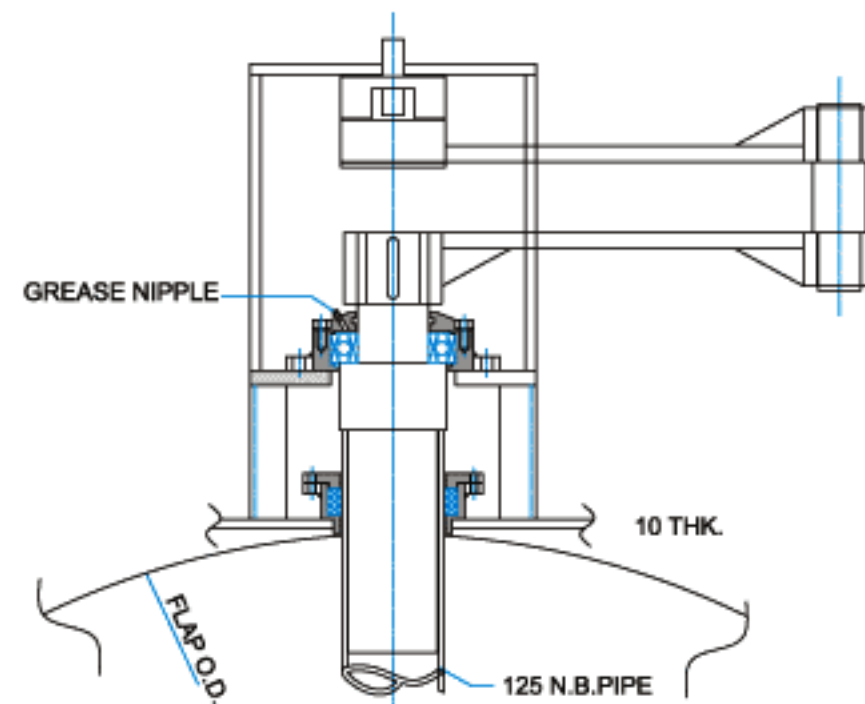

Through D Type Shaft

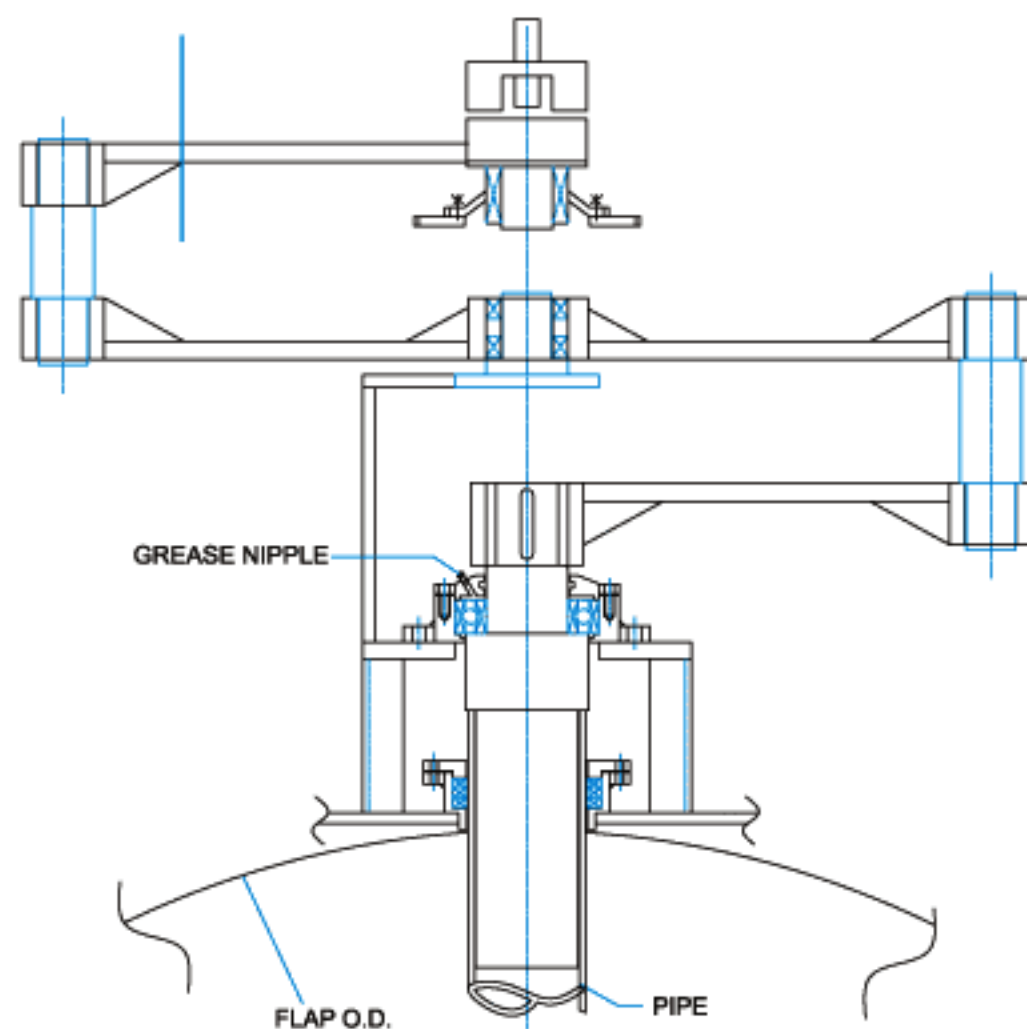

Through Link Multiplier

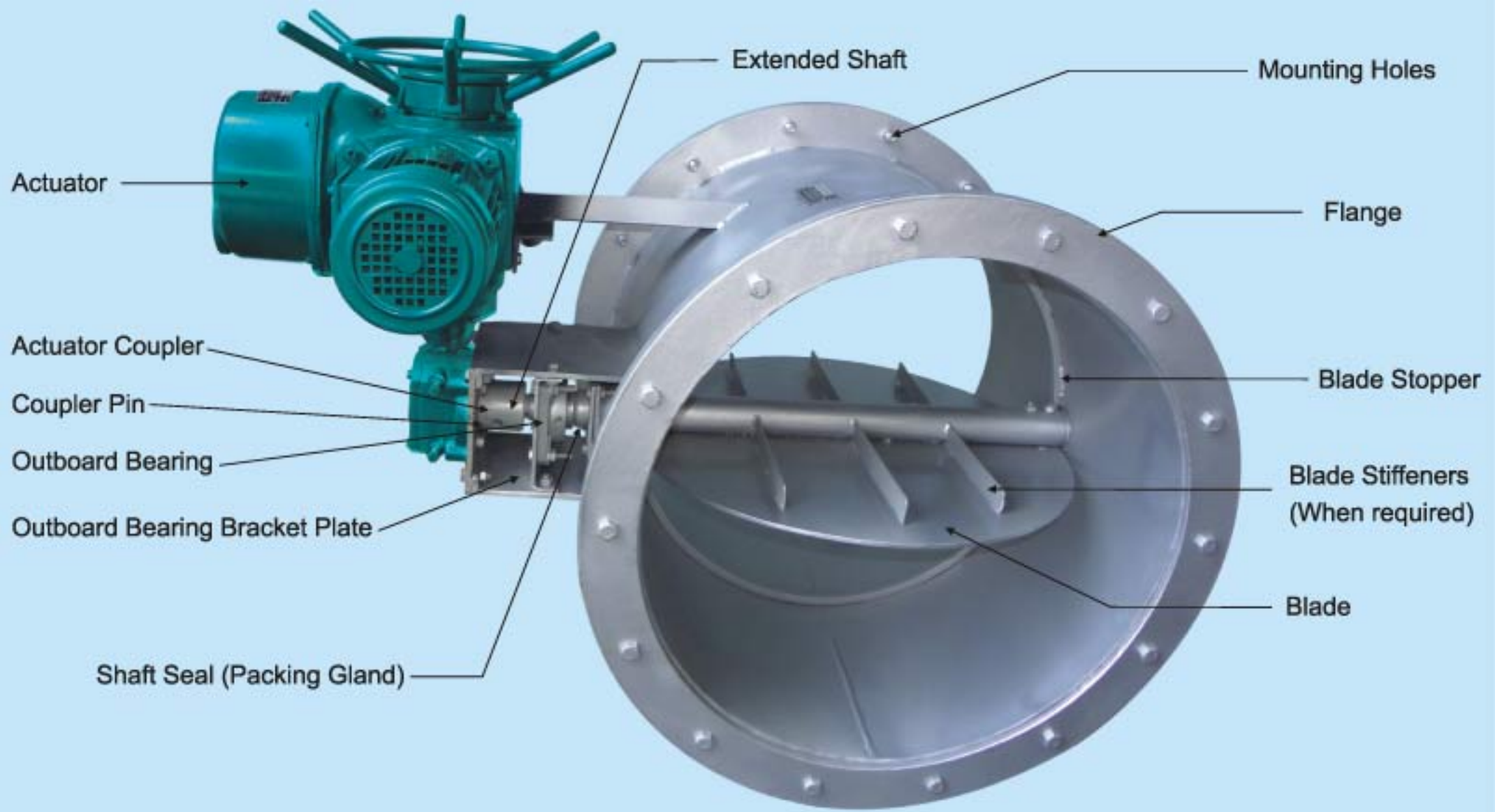

Figure 3 a : Different Parts of Round Butterfly Damper

Figure 3 b : Pneumatic actuated Butterfly Damper-low leakage construction



Figure 3 c : Three phase Electric actuated Butterfly Damper-low leakage construction



Sizes :

Any sizes can be made since they are fabricated.

Frame :

Mild steel body confirms to IS2062, and Boiler grade steel confirms to IS2002 with continuous welded flanges and alternatively Stainless steel, aluminum or any other weld able material. Structural channel is available for larger size dampers. Structural channel, angle or special dimensions formed channel in any weld able material. We can provide any dimensions for your special retrofit application.

Vanes :

Mild steel or any other material based on customer's requirements, double thick air-foil vanes, welded to

through shaft, and single thick plate offset and formed at shaft for extra strength, reinforcing ribs are provided as required for intended service. The vane is welded to a continuous thru shaft alternatively Stainless, corrosion and abrasion resistant materials.

Shafts :

Shaft ends are marked to indicate vane position and it is made up of stainless steel continuous or stub shafts.

Bearings :

Ball/Bush bearings mounted outboard on stand-offs, over adjustable packing glands. For high temperature application the carbon sleeve bearings are used in such condition the stainless steel shafts are recommended

Linkage :

Heavy duty, non-adjustable, bar linkage mounted outboard with a bronze bushing and shoulder bolt connection at each pivot point for Parallel or opposed blade action. Adjustable linkage with threaded rod and pipe linkage bars and rod end bearings.

Parallel blade operation is preferred when the damper makes up a significant portion of the total system pressure loss. Parallel blades are used when greater control is required near the top end of the volume operating range or for systems requiring two position (fully open or fully closed) operation. Parallel blades should not be used upstream of critical components due to uneven airflow. Refer Figure 4a

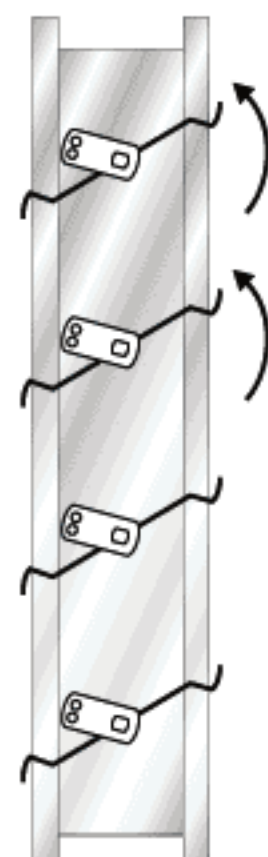

Figure 4 a

Opposed blade operation offers the best control over the entire operating range when the damper doesn't make up a significant portion of the total system pressure loss. Opposed blades are used for applications where it is necessary to maintain even distribution of air downstream from the damper. Opposed blades are the best selection for ducted outlets. An opposed blade operation must be open further to obtain the same resistance to airflow as a parallel blade damper. Refer Figure 4b.

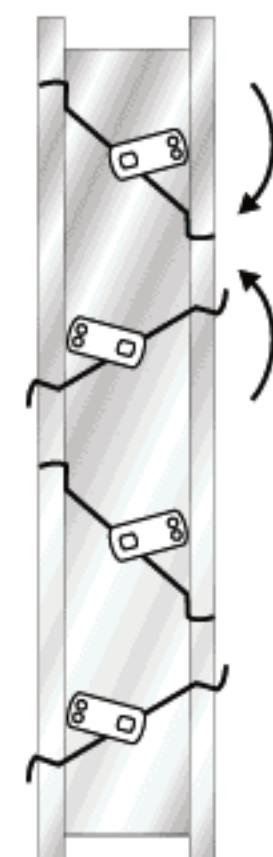

Figure 4 b

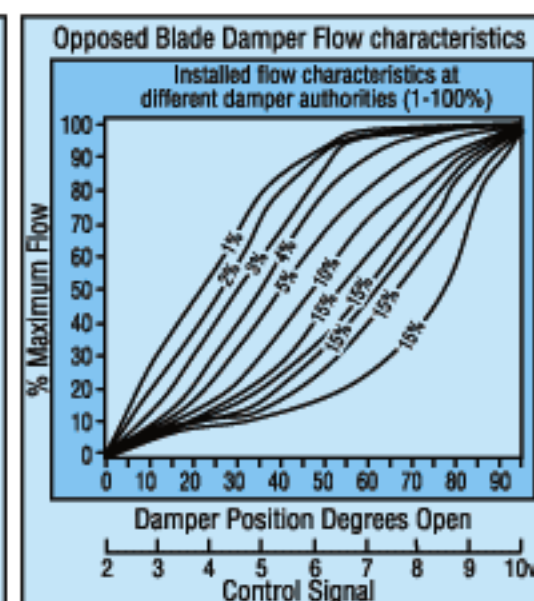
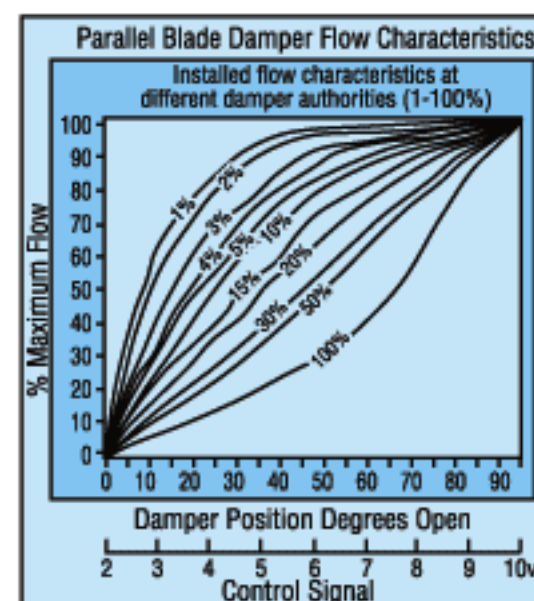
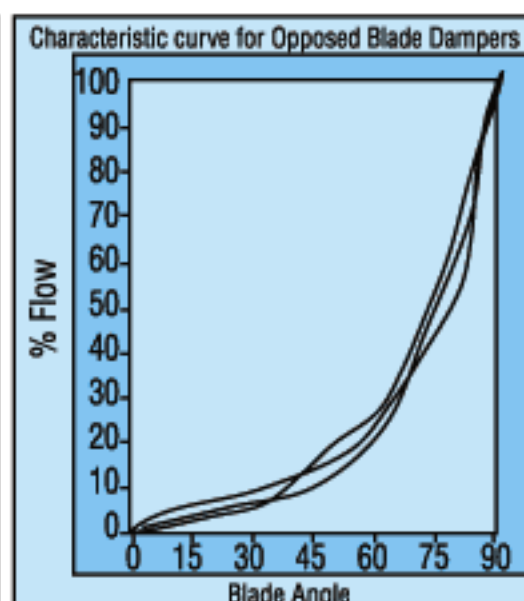
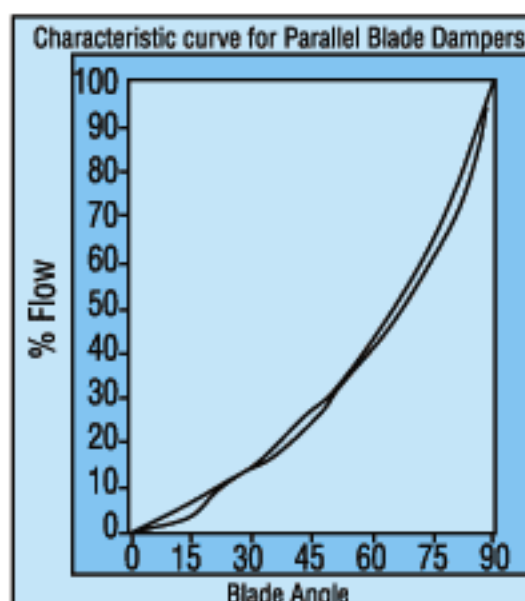

Figure 4 c : Flow characteristics curve of Straight & Opposite Blades.

Square / Rectangular Dampers (Multi Louver & Butterfly)

Heavy duty industrial grade louver dampers are available with parallel or opposed action linkage for isolation and/or control of process air and gas. Refer figure 4d.

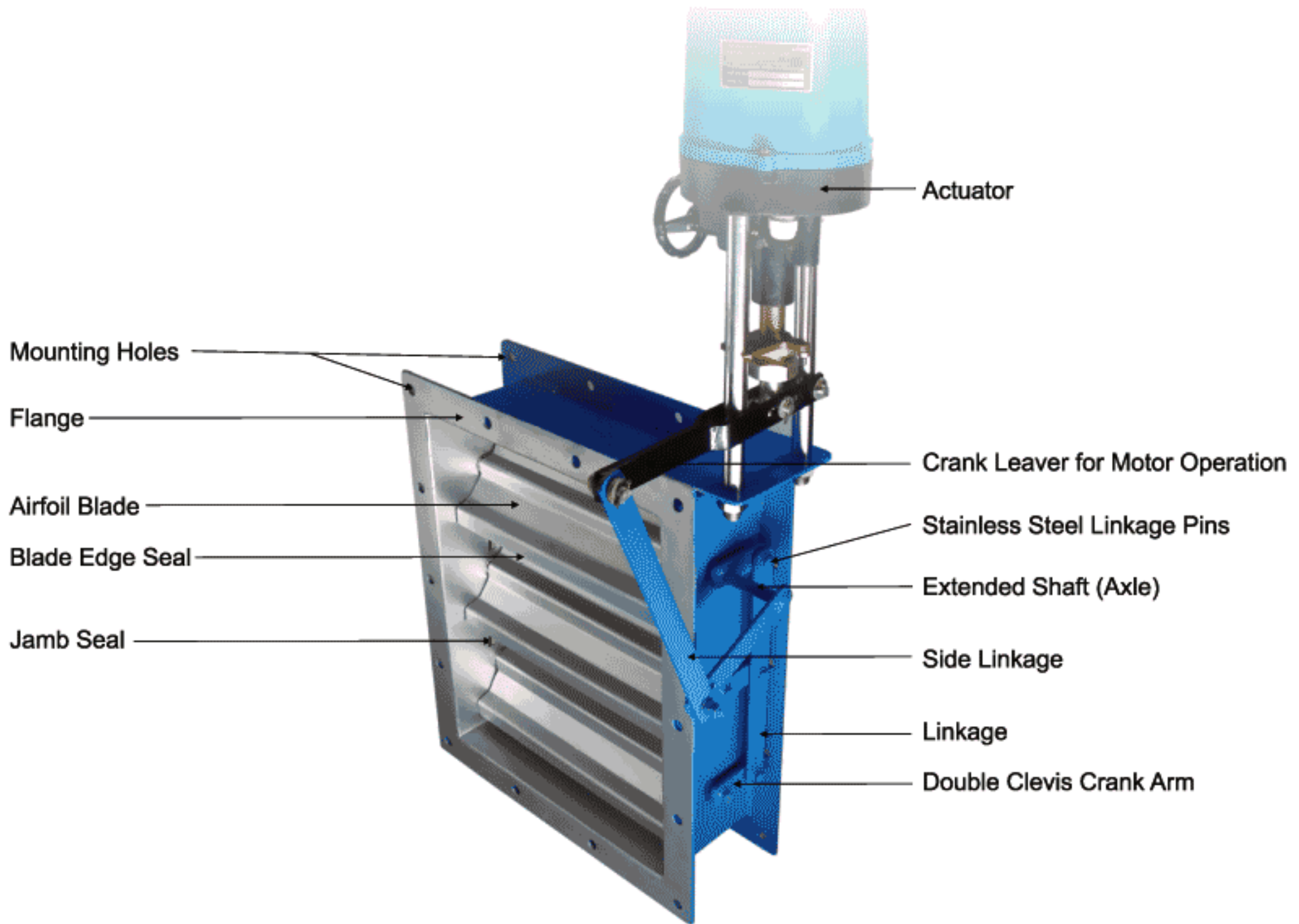

Figure 4 d : General Arrangement of Square / Rectangular Damper - Parallel Blade

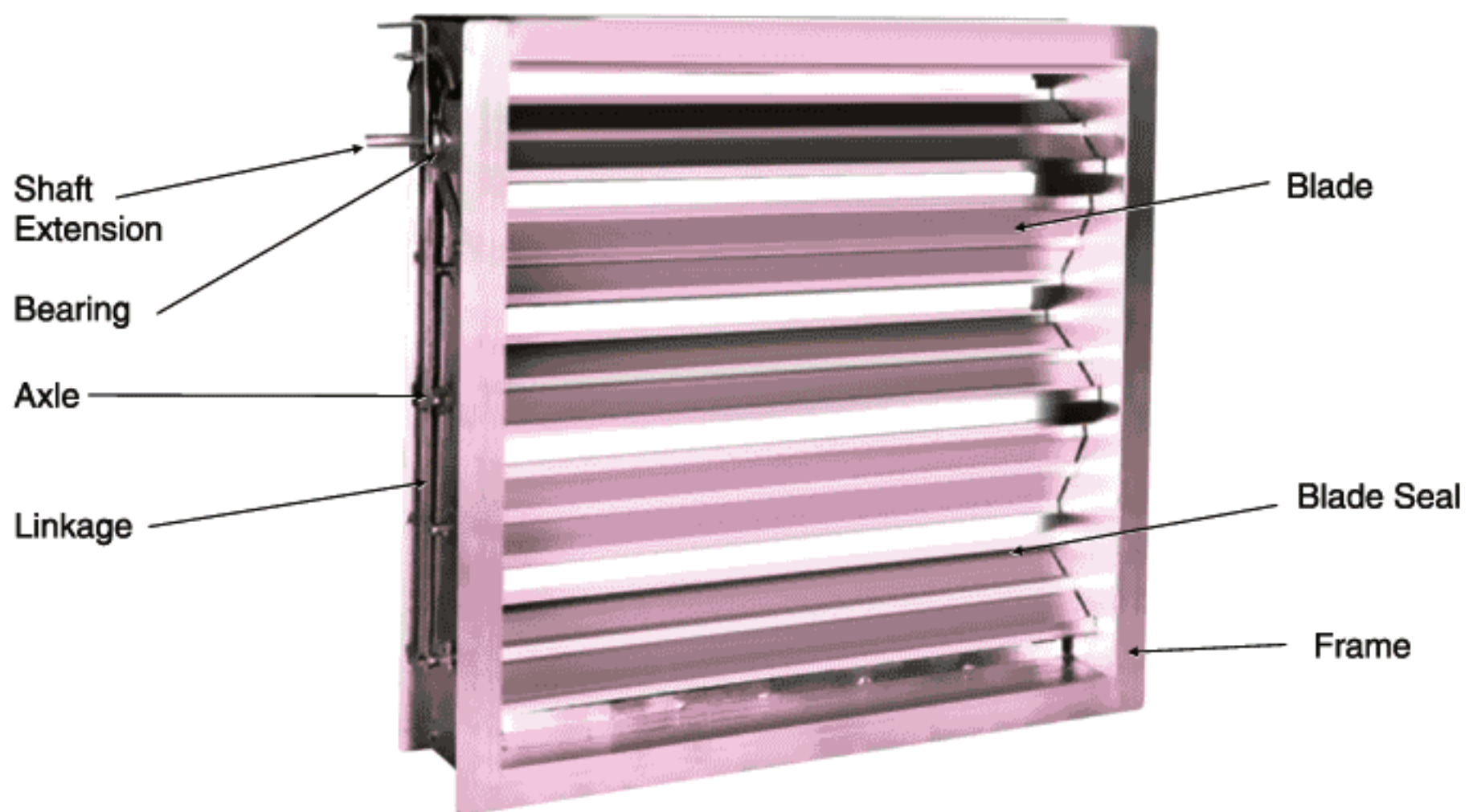

Figure 4 e : General layout assembly of Square/Rectangular Damper - Opposite Blade

Seals:

No internal vane seals provided. Swing clearance between vanes and frame for approximately 98% shut-off when fully closed.

Paint:

Damper is hand cleaned and painted one shop coat of our standard industrial primer, or we also do the painting as per customer's specification.

Operator:

Extended operator shaft is provided for operating it with Pneumatic or Electrical actuator based on customer's requirements. Wide range of Manual Electric & pneumatic operators with options for modulating, failsafe, switches, etc available and they are assembled based on customers specification.

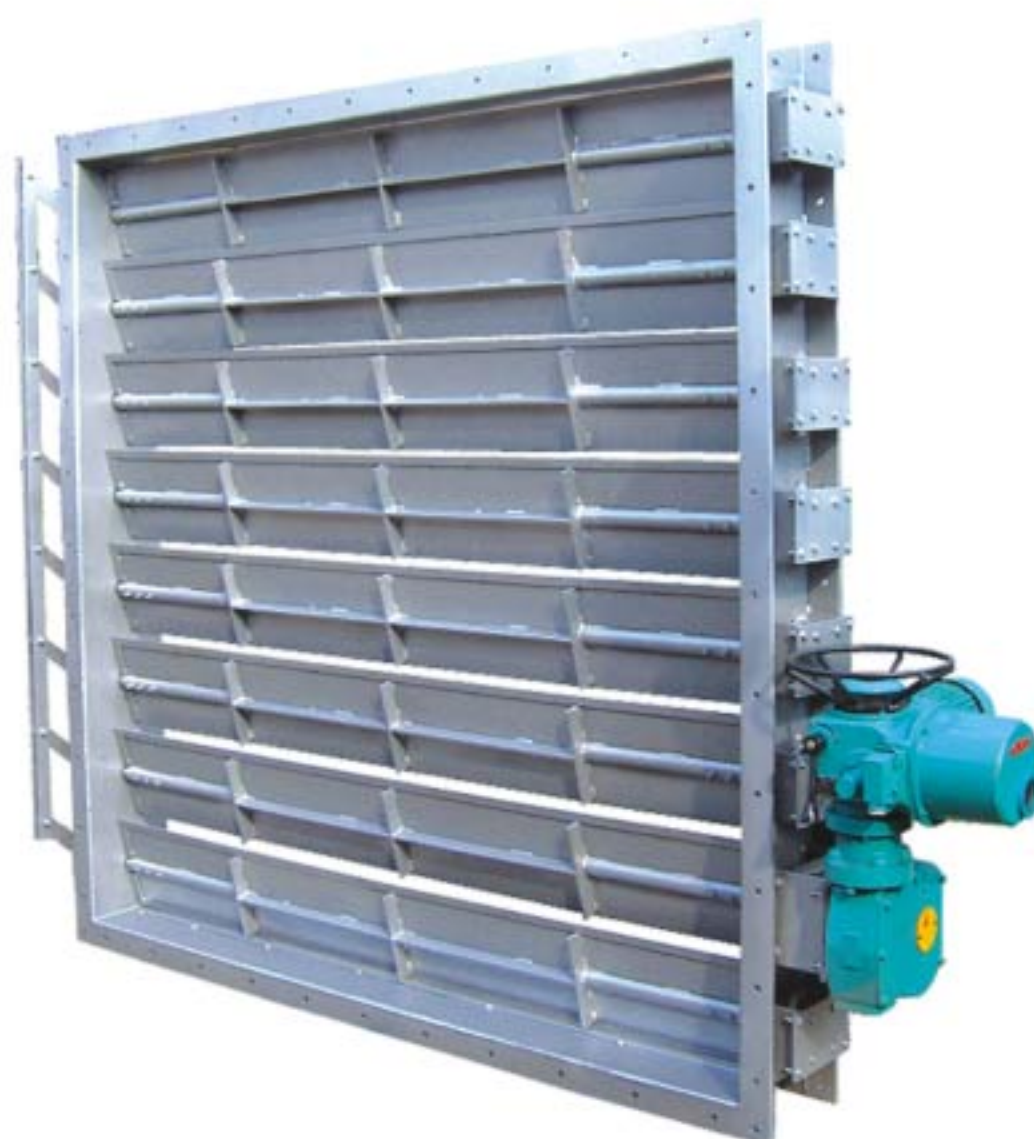

Figure 4 f : Pneumatic Actuated Rectangular Damper.



Figure 4 h : Single phase Electric actuated Rectangular Damper.

Figure 4 g : Three phase Electric actuated Rectangular damper



As a special case we also offer Castable refractory linings, heat shields, position indicating switches, slave linkages.

Instruction For Installation / Maintenance of Round Damper:

Dampers can be mounted on the inlet or on the Discharge. If mounted on the inlet there must be sufficient space between the damper and the fan to ensure a constant flow towards the impeller. In case a damper is directly mounted on the inlet it can only be used as start-up damper. If the element is directly connected at the discharge the position of the rotation axis has to be observed refer figure 4 i

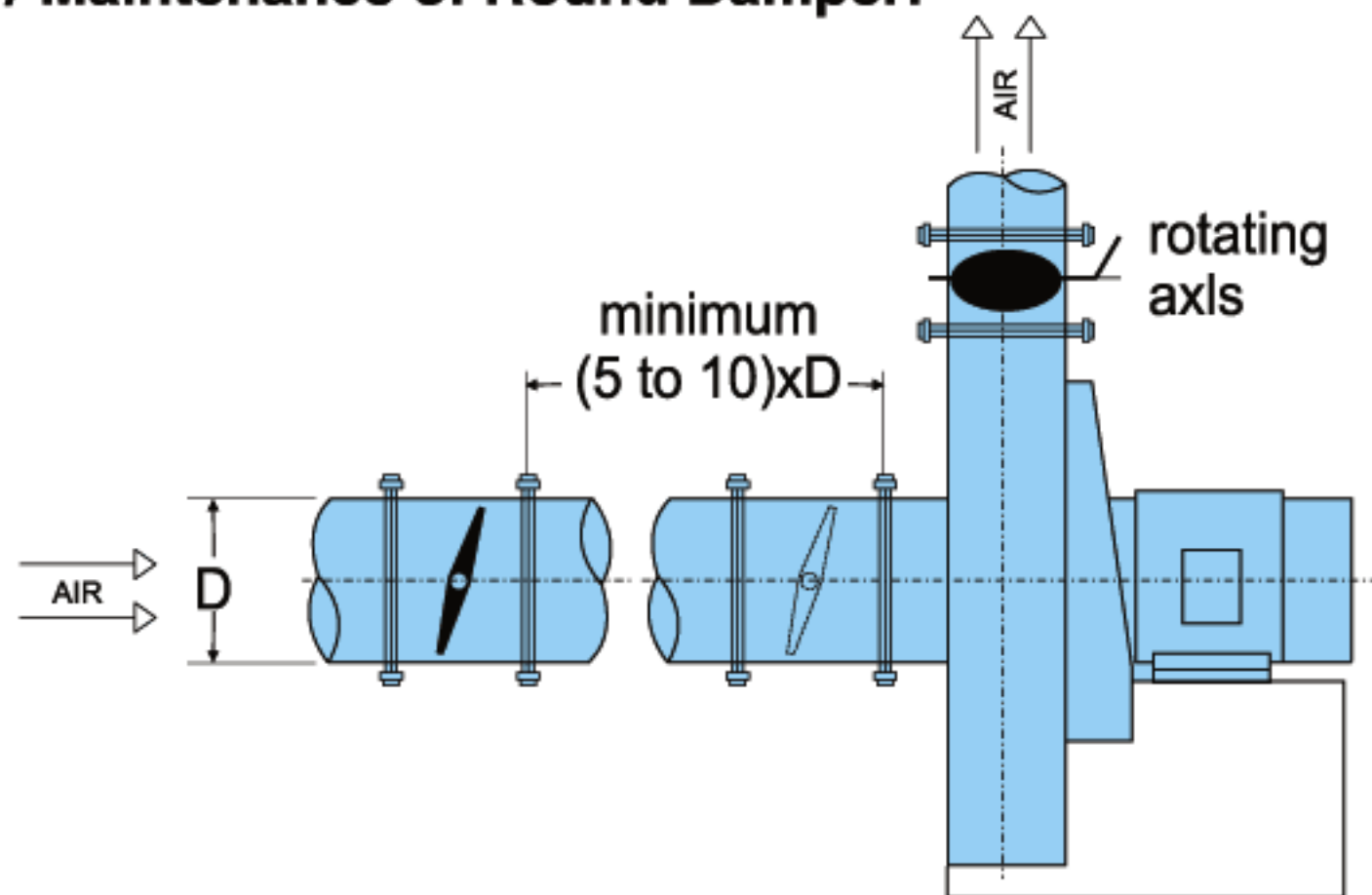

Figure 4 i : Installation of Round Damper

Miscellaneous Options:

- Inlet screens, mating flanges, special duct sections. (tees, transitions, weather hoods, etc.)
- Cast able refractory linings were Sude specialization plays a major role for proper treatments, heat shields, position indicating switches, slave linkages etc. or in short we can offer the complete system integration to customer's specification.

Application

Air control dampers are designed for use in all HVAC/Industrial application where accurate flow control is required. Their unique drive mechanism ensures long life maintenance free operation in constantly modulating installations. They are also suitable for industrial application where gas and dusty air has to control.

Instruction For Installation / Maintenance of Square / Rectangular Damper

Rectangular dampers can be directly arranged at the discharge or at any other place within the plant. If directly mounted on discharge the position of the rotation axis has to be observed. Refer figure 4 j

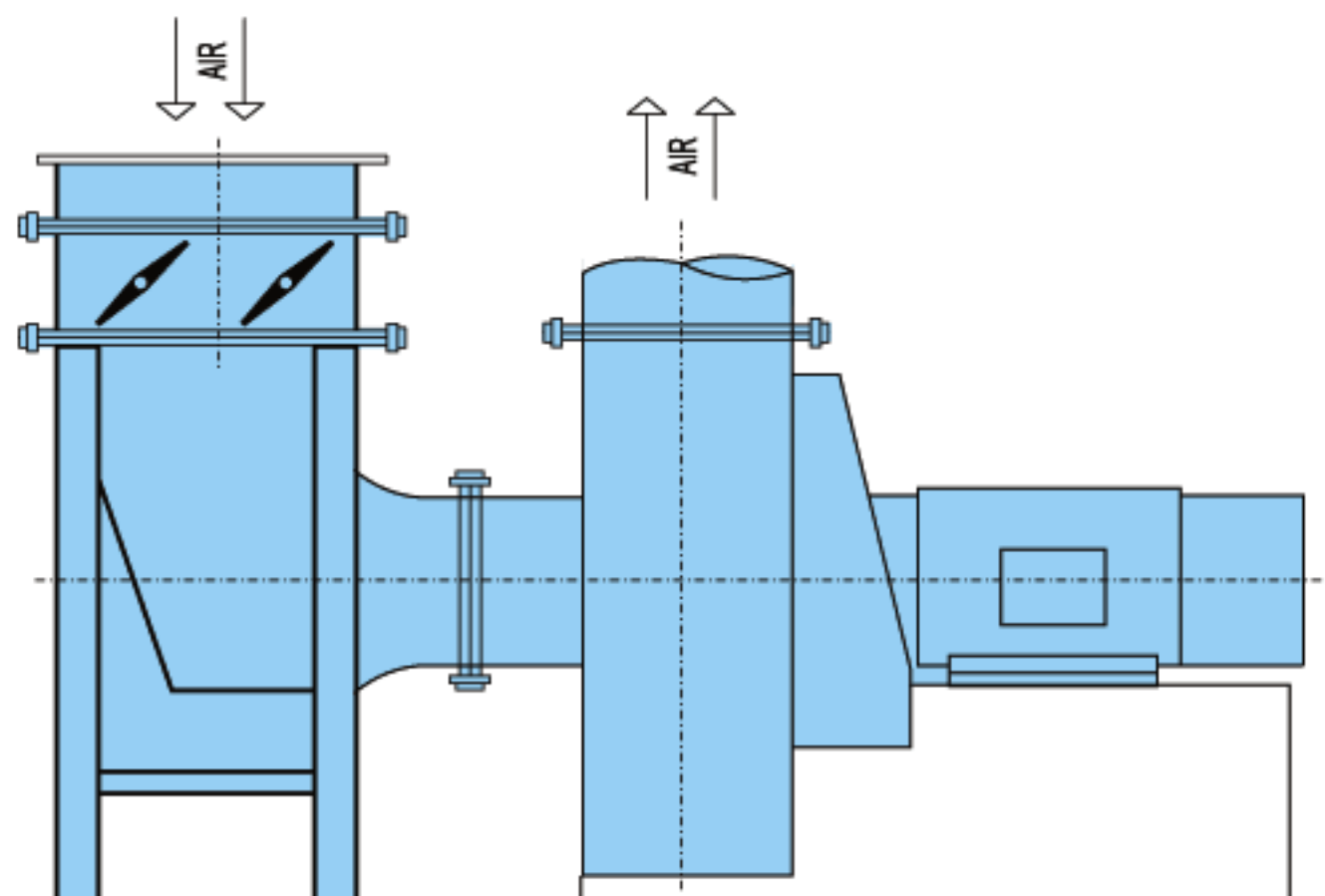

Figure 4 j : Installation of Rectangular Damper.

There are two versions for the arrangement directly at inlet: For a width of up to 2,000 mm the rectangular damper is arranged in longitudinal direction of the suction box. If width is > 2,000 mm the damper will be arranged laterally to the suction box. Blade adjustment is available in parallel or reverse direction. Refer figure 4 k.

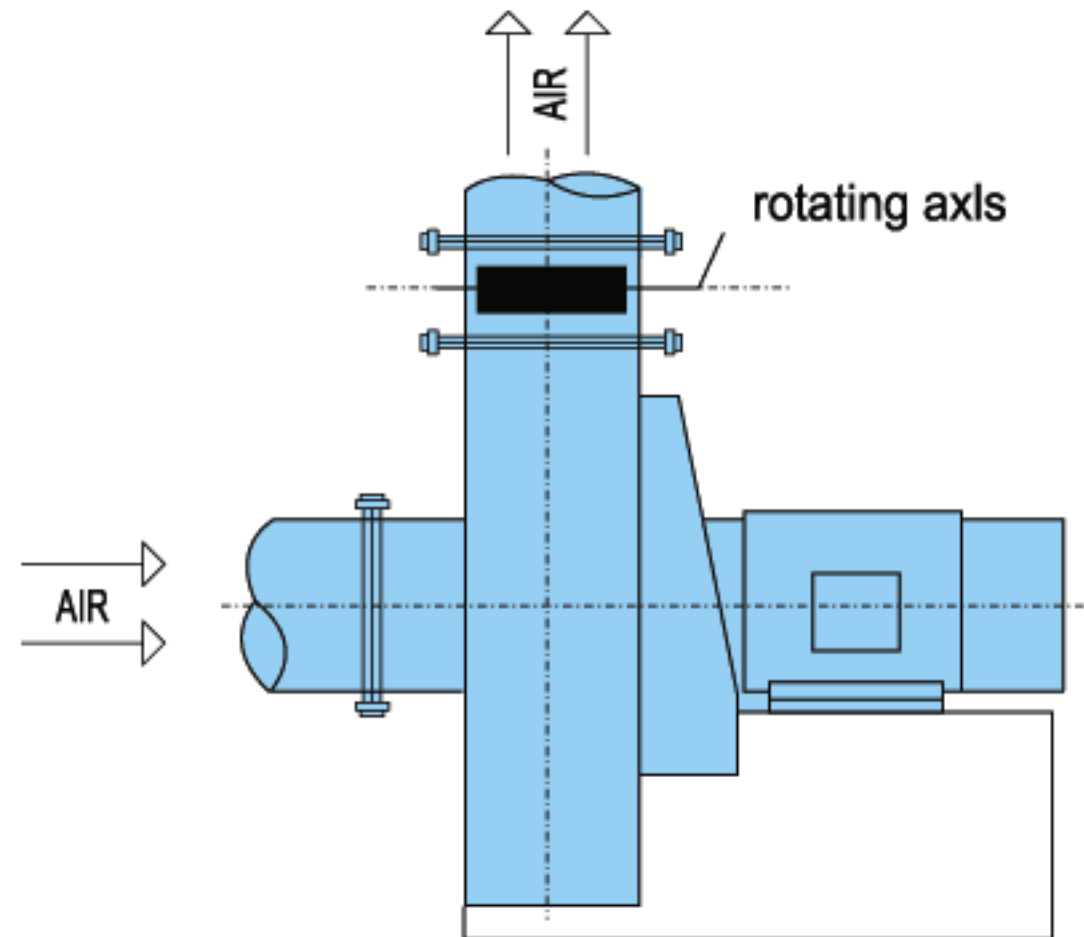

Figure 4 k : Installation of Rectangular Damper.

Characteristic Range of Round & Rectangular Damper.

Reduction of flow by a Butterfly damper or Rectangular damper is the easiest method; however it also involves the highest losses. The resulting pressure losses correspond to the angle size of the damper vanes. The more the damper closes the greater the pressure loss is thus generating an additional resistance and an alternation of the plant's performance curve. The fan's power requirement curve is not affected. Refer figure 4 l.

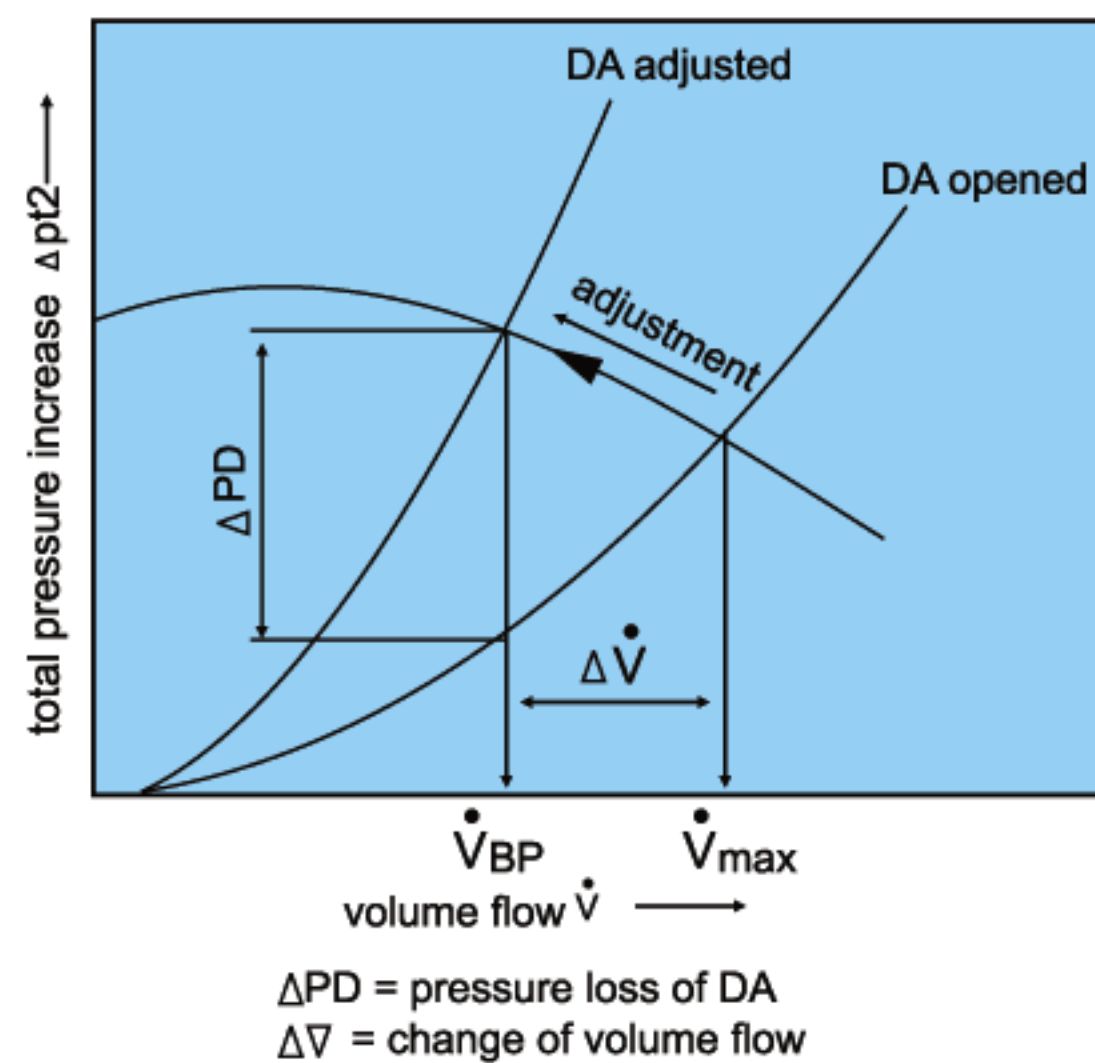
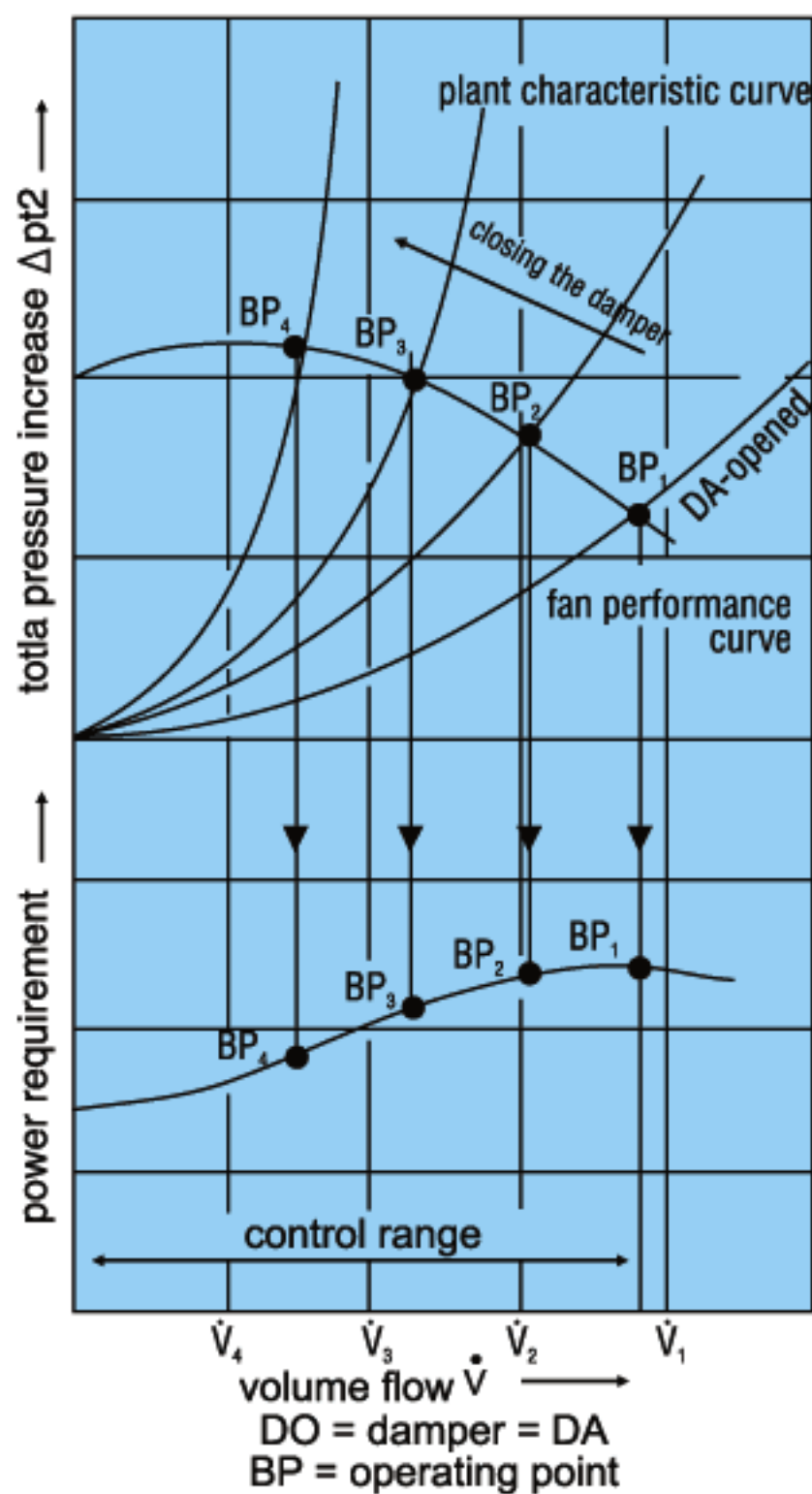

Figure 4 l : Relation between Flow, Static pressure & Break horse power generated by Blower

Variable Inlet Vane Damper

Variable Inlet Vane (VIV) dampers also called guide vane too are often used for capacity modulation. They give accurate modulation and power savings over other styles of dampers at reduced air flow. Refer figures 5a, 5b

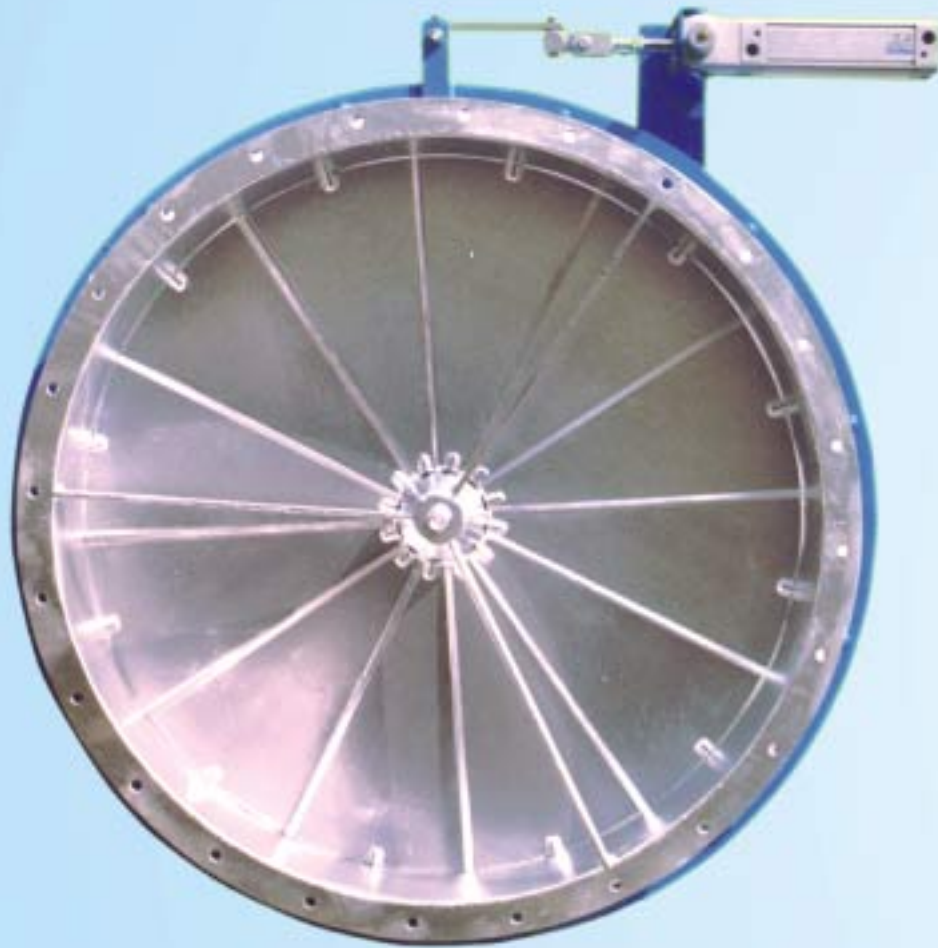

Figure 5 a : Pneumatic actuated Guide vane Damper.



Figure 5 b : Three Phase Electric Actuated Guide Vane Damper



Single Phase Electric Actuated Guide Vane Damper

For every inlet vane position there is different capacity v/s static pressure curve and capacity v/s brake horsepower curve generated by the blower.

When an inlet vane is partially closed, each blade directs the air into the impeller in the direction of rotation. This brings about a reduction in the capacity, static pressure and BHP. The amount of BHP savings at reduced capacity is determined by the type of system and type of blower-vane combination.

Key Attributes

- Inlet guide vanes are synchronously adjustable in the same angular position by a connecting element.
- Adjustment can be made either automatically via an adjusting element by pneumatic / electrical or hand.

Variable Inlet Vane (VIV) dampers are often used for capacity modulation. They give accurate modulation and power savings over other styles of dampers at reduced air flow.

For every inlet vane position there is different capacity v/s static pressure curve and capacity v/s brake horsepower curve generated by the blower.

Characteristic Range of VIV Damper

Compared to the Butterfly damper and Rectangular damper the inlet guide vane provides much better control. Dependent on the position of the blades the inlet guide vane generates a pre-whirl which changes the fan's performance curve. The power requirement curve of the fan also changes accordingly to the change of the angle. The direction of the pre-whirl must always be the same as the direction of the fan's rotation. (Refer Figure 5 c)

Stall At Guiding Blade of The Inlet Guide Vane

Excessive reduction of flow by an inlet guide vane will result in a critical stall at the guiding blades but only under certain conditions. These are unfavorable flow conditions and a small range of angle when the guiding vanes strongly to almost closed.

Such critical stalls are avoided by an optimal design of the aerodynamic inflow and by not setting the vanes to the special critical angle. That is to say, chose an optimal fan size (i.e. the performance curves of the system and of the fan meet in calculated operating point) and a control range in the top 2/3 of the inlet guide vane position. Setting the inlet guide vane to $>60^\circ$ should be avoided by all means.

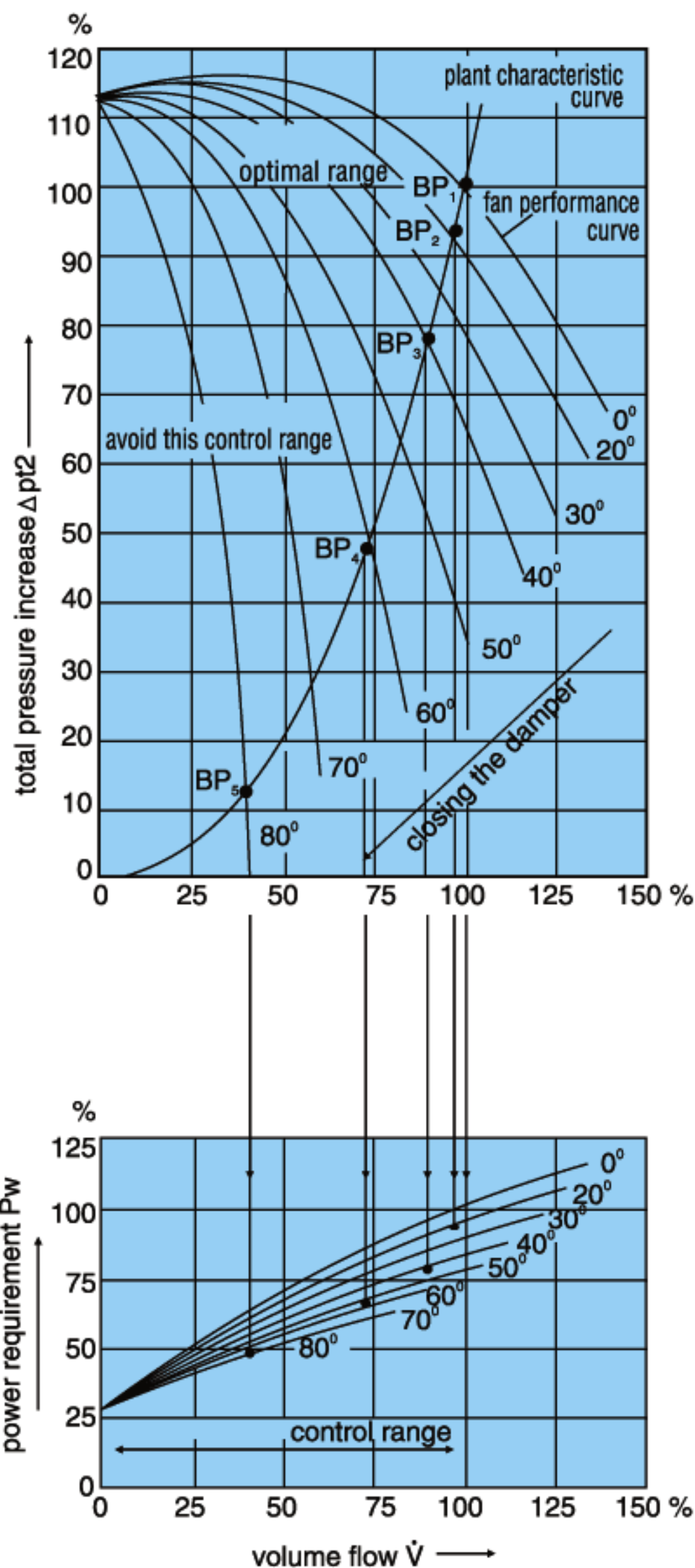

Figure 5 c : Relation between Flow, Static Pressure & Break horse power generated by Blower

Application

Used in combination with blowers for capacity modulation.

Features:

- High efficiency when dampered.
- Minimizes rotating stall.
- No need to extend bearing centers.
- Tapered boxes are possible.
- Mechanism in air stream.
- Requires cone-shaped inlet piece design.
- Sizes available in excess of 2000 mm in diameter and the higher sizes can be made on request.
- Flange mount frame to allow bolting to fan.
- Open, capped or bullet nose hub to increase performance.
- Standard 3mm steel channel frame (heavier construction options available).
- Standard design operation to 120°C (higher temperatures attainable through variations in design).
- **Material** : Material construction will remain same as explained under Butterfly and Rectangular dampers.
- **Bearings** : All details are same as explained under Butterfly and Rectangular damper's
- **Operator** : Fiberglass manual locking hand and also automated through Electrical and pneumatic actuator.
- **Extended Shaft**
- **Flat Capped Hub**

NOTE

Inlet air rotation, clockwise or counter clockwise, is determined from air inlet side of fan.

Instruction For Installation / Maintenance of VIV Damper

Inlet guide vanes always have to be arranged at the inlet. To reduce losses we recommend the installation of a guarded inlet nozzle. Further, the direction of the pre-whirl (viewed towards the inlet guide vane) must always point towards the rotation direction of the fan. Refer figure 5 d.

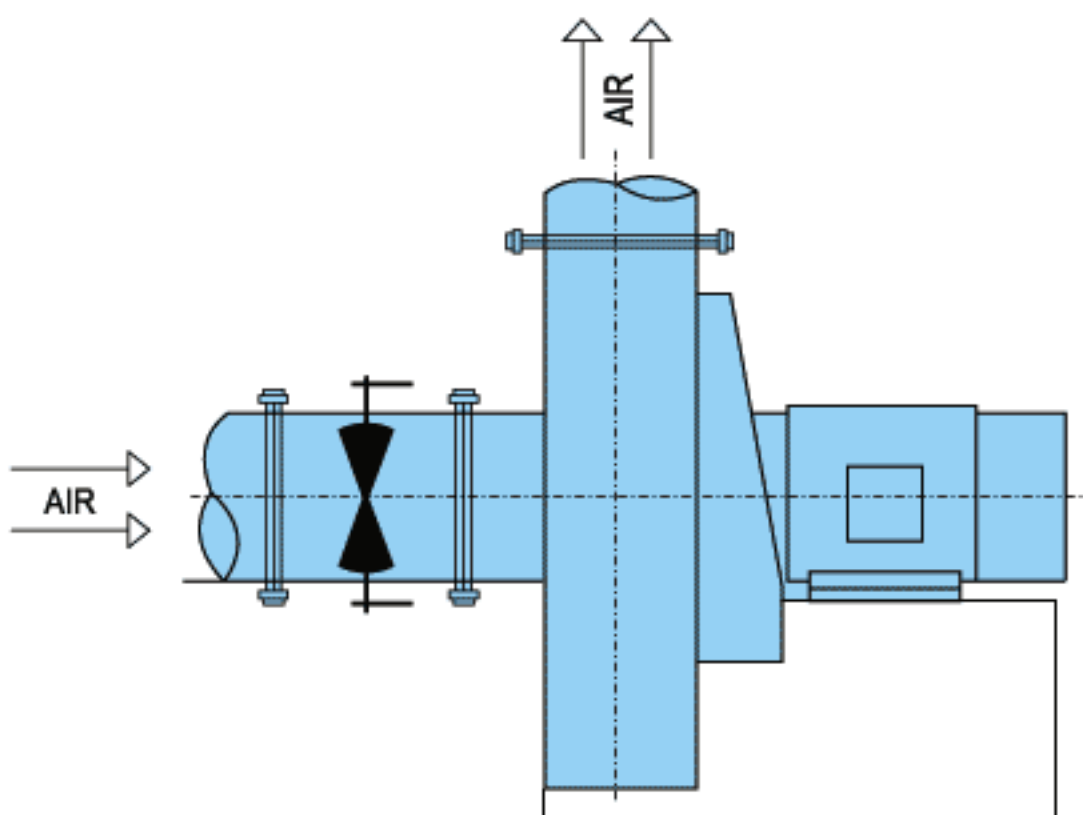

Figure 5 d : Installation of VIV Damper.

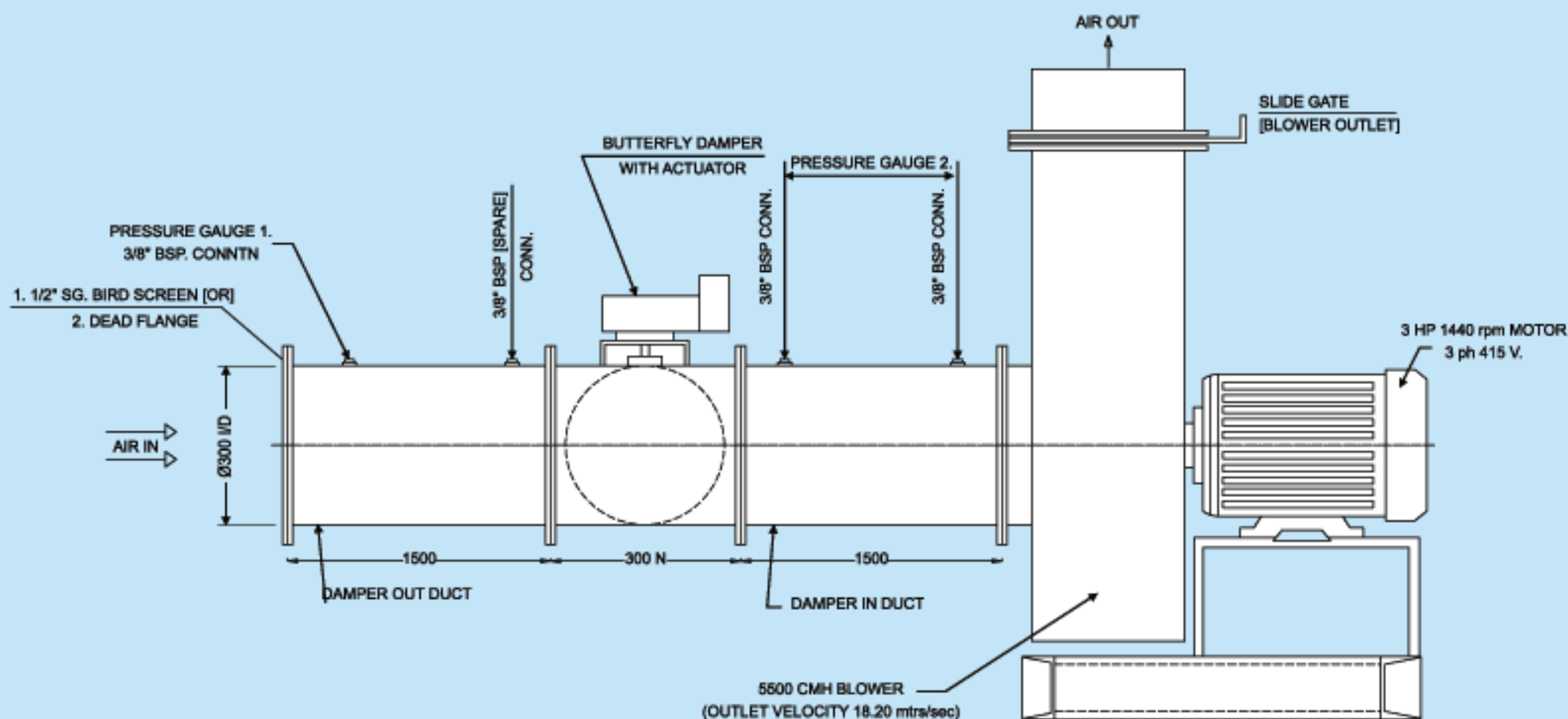

Figure 6 : Test Bench for Dampers efficiency check

Title	Test Bench For Damper
Duty	To Check Sealing Efficiency of Damper
Air Throttle Device	Slide Gate at Blower Outlet (To Control / Regulate the Required Air Quantity)
Pressure Gauge	Manometer OR Dial type Differential Pressure Gauge (To Check Pressure Across the Test Damper)
Testing Procedure	<p>Mount The Test Damper in the Test Bench</p> <p>Ensure The Test Damper in Open Position</p> <p>Ensure The Slide Gate Damper at Blower Outlet in Open Position</p> <p>Start The Air Supply Blower</p> <p>Regulate the Air with the help of Slide Gate Damper at Blower Outlet to required Air Quantity & Face Velocity</p> <p>Measure the Air Quantity & Velocity with the help of Velometer</p> <p>Actuate the Test Damper to Tight Shut Off</p> <p>Measure the Air Quantity & Velocity at Test Damper Outlet Side Duct</p> <p>Check the difference of Air Quantity at Test Damper Open Position and Close Position</p> <p>Close the Outlet Side Duct with the help of Dead Flange</p> <p>Measure the Pressure at Test Damper Inlet side Duct</p> <p>Measure the Pressure at Test Damper outlet side Duct</p> <p>Check the difference of Pressure at Test Damper Inlet side Duct and Outlet side Duct</p>
Result	By calculating the Difference between Air Quantity / Pressure Velocity we can conclude the Efficiency of Test Damper.

Complete Control Solutions

Sude Engineering is known in the industry for wide variety of cost-effective solutions for dampers, actuators and damper retrofitting. Our commercial and industrial actuation, dampers can be part of your complete solution. Be sure to ask us for project pricing to fill all your needs.

Features include:

- Ability to withstand 0.1 bar static pressure with blades closed at fan shut-off.
- Operate in temperatures up to 300°C and with lining up to 1000°C.
(Refer Figure 7, further high temperature refer Sude)
- Fan discharge and fan isolation.
- Electric or pneumatic actuation.
- Elevated temperature construction.

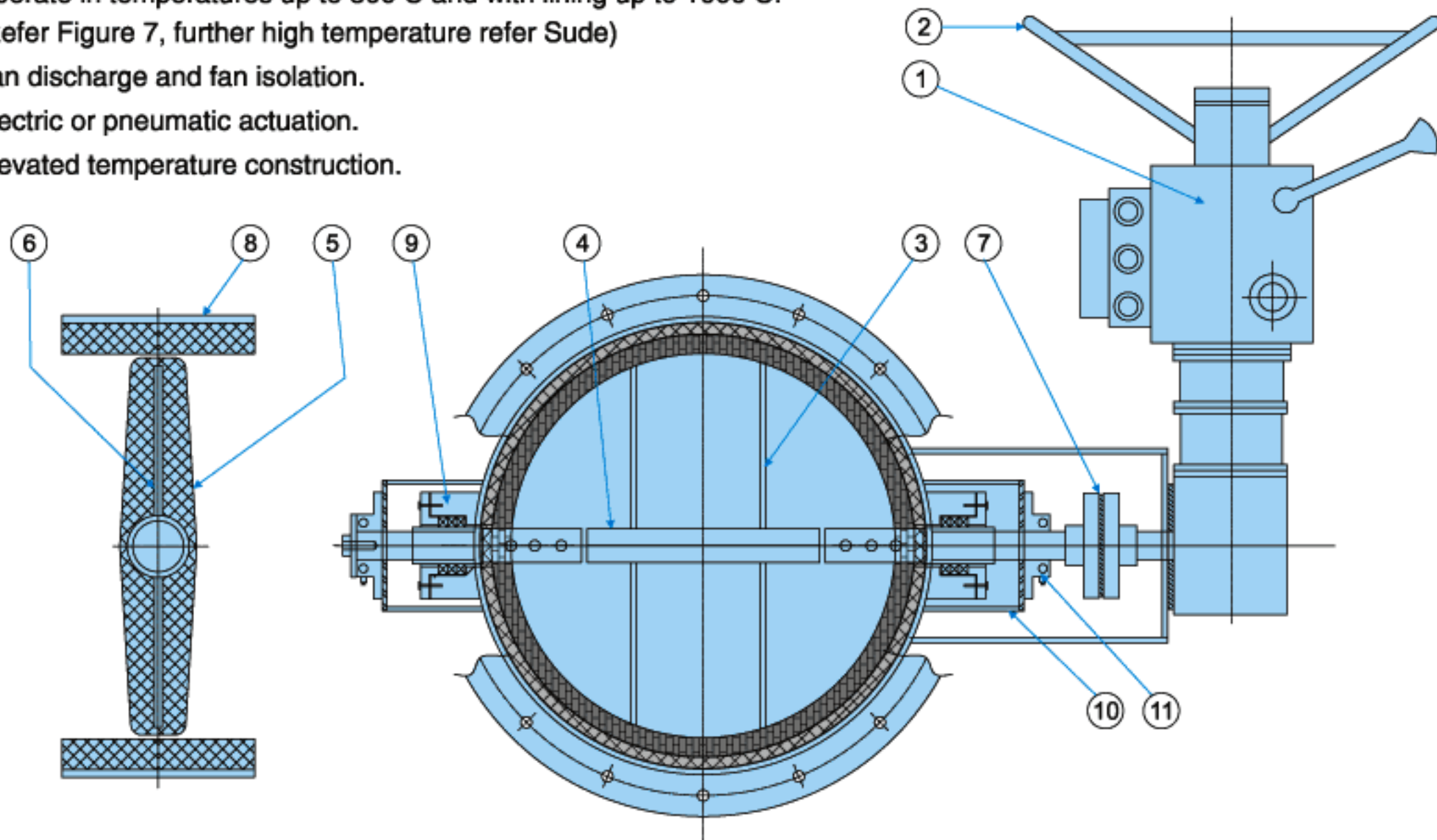

Part No.	Description
1	Electrical Actuator
2	Hand Wheel
3	Flap with Stiffner
4	Stub Pipe
5	Heat 'K' Lining
6	Flap
7	Link Assly.
8	Casing
9	Stuffing Box
10	Bracket for Bearing
11	Bearing

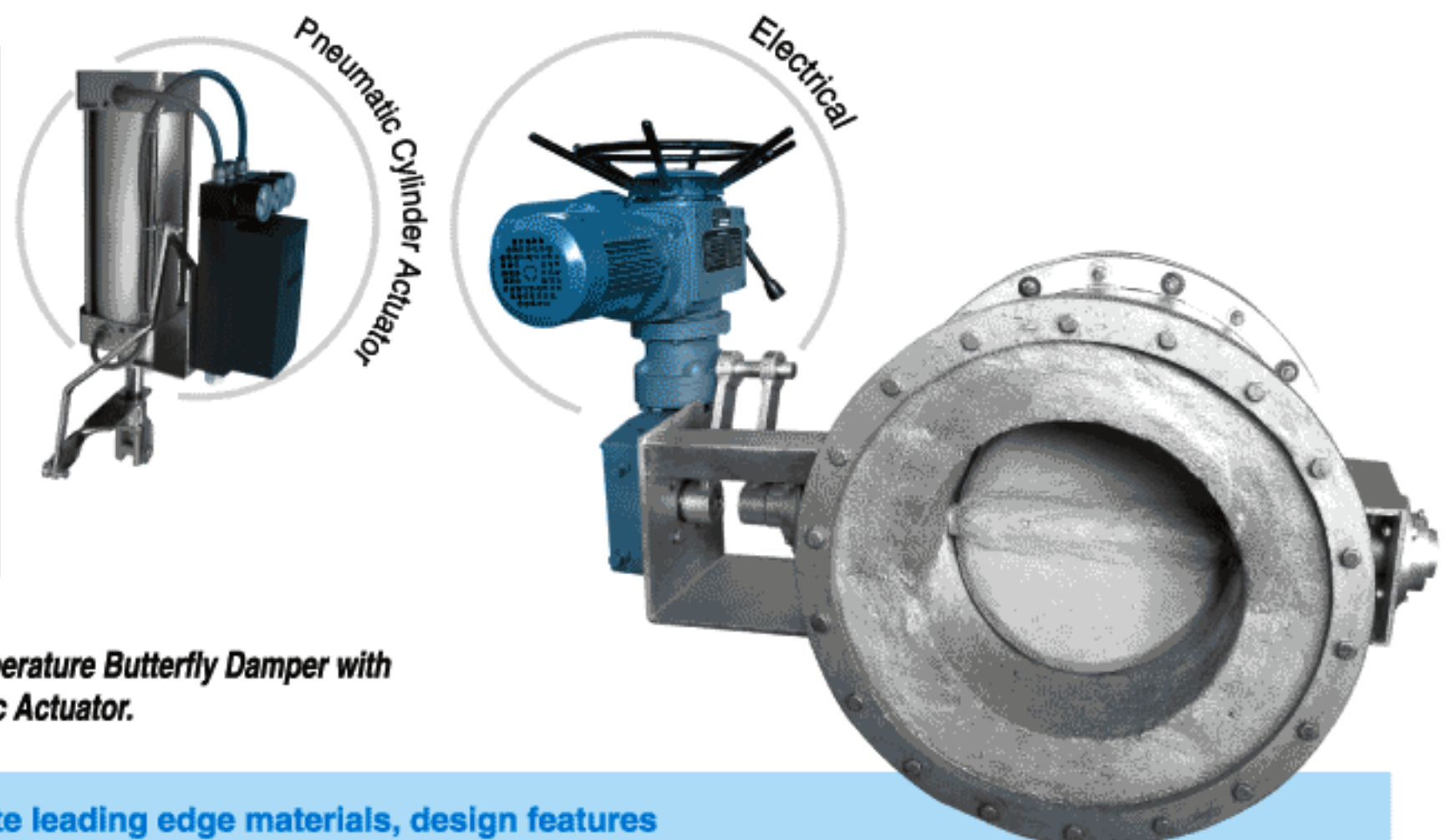

Figure 7 : Single Flap High temperature Butterfly Damper with Three Phase Electric / Pneumatic Actuator.

Sude dampers incorporate leading edge materials, design features and performance. A complete range of drive systems and sealing options are available.

Sude Engineering offers a full line of rugged, reliable dampers to provide critical, man-safe isolation and or control of airflow in utility, refinery and industrial process applications.

Designed to permit inspection and maintenance during plant operation, these custom engineered and manufactured dampers eliminate costly down time and lost production.

Sude round dampers are designed for control of air flow in round ductwork. They have all fiberglass reinforced construction for greater resistance to corrosive environments if application demands.

Diverter Damper

Dampers shall be butterfly type consisting of circular blade, mounted to axle within formed flanged frame. Frames shall be constructed of 304 Stainless Steel or any other material specification channel and shall have full circumference blade stop located in air stream. Damper shaft shall be continuous, solid-cold rolled Stainless Steel extending through the entire diameter of damper and beyond damper bearing a minimum of six inches or higher depending on the application. Axle shall be supported and sealed, relubricable ball bearings mounted to damper frame. Press fit bearings are not advisable. Damper frame and blade shall be fabricated from Stainless Steel or any other material as per customer's specification.

Damper leakage shall not exceed 1.4% of the maximum airflow.

Heavy duty industrial grade butterfly dampers are custom designed for use in high temperature and pressure applications where special flanges and other custom features are required.

Designs and material options are available for higher temperatures and pressure.

We can build our butterfly dampers integrally into a 'T' or 'Y' duct section with an operator mounted to one damper and a slave linkage to the other damper. The linkage can be arranged so that as one damper opens, the other damper will close, these are widely used for process air or gas diversion applications. The complete pre-assembled and adjusted unit is shipped to the job site for easy installation, saving time and cost.

'Y' Type Single Flap Diverter Damper

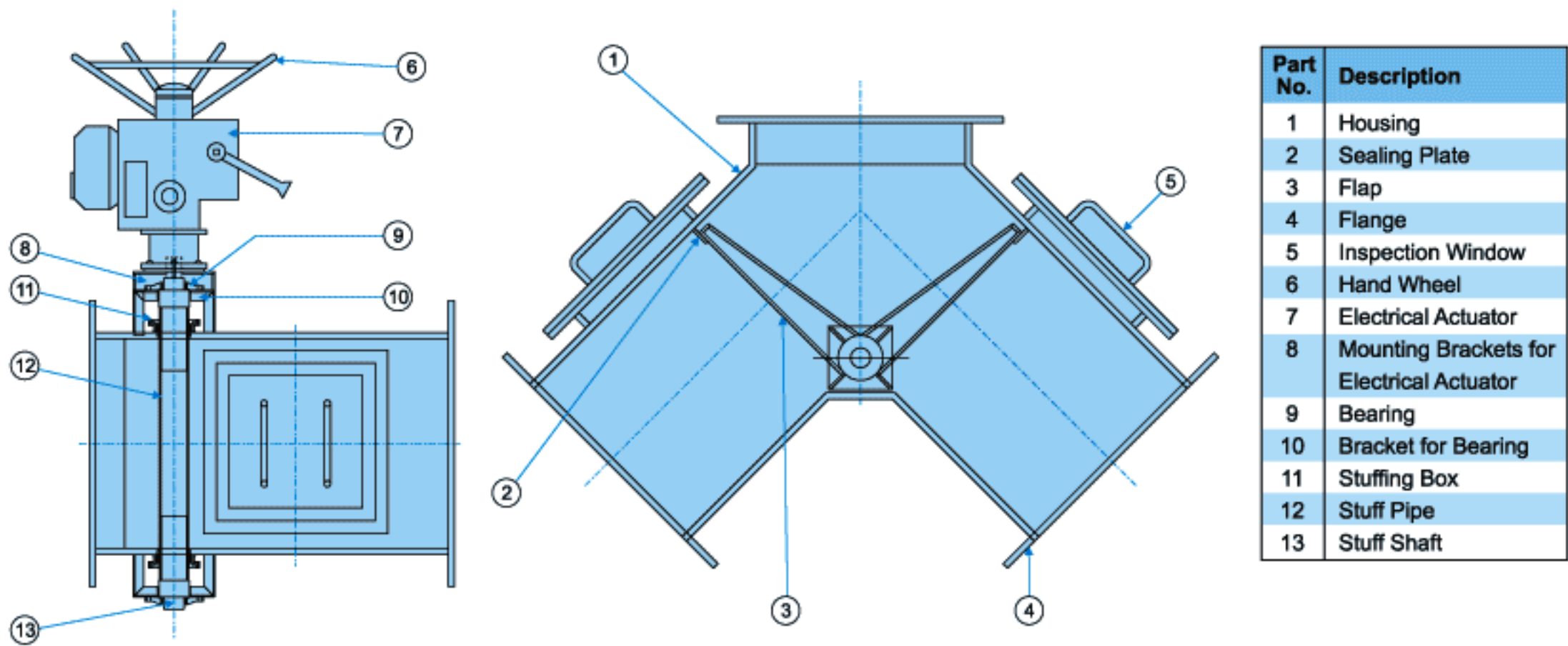

Figure 8 a

For smooth flow Diverter Damper can be lined with ultra high molecular, high density polyethylene/Cast Nylon.

'T' Type Double Flap Diverter Damper

SUDE

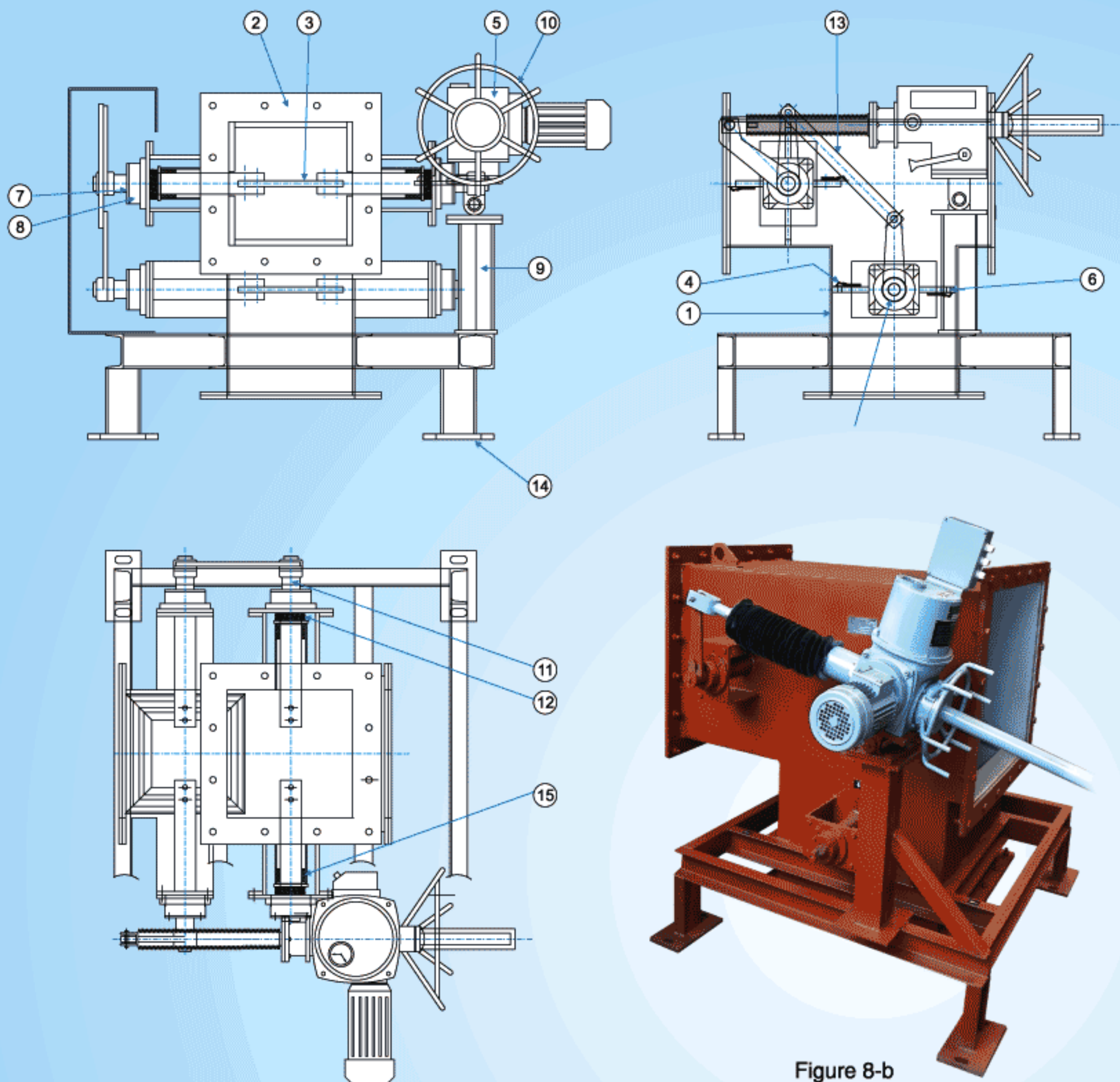
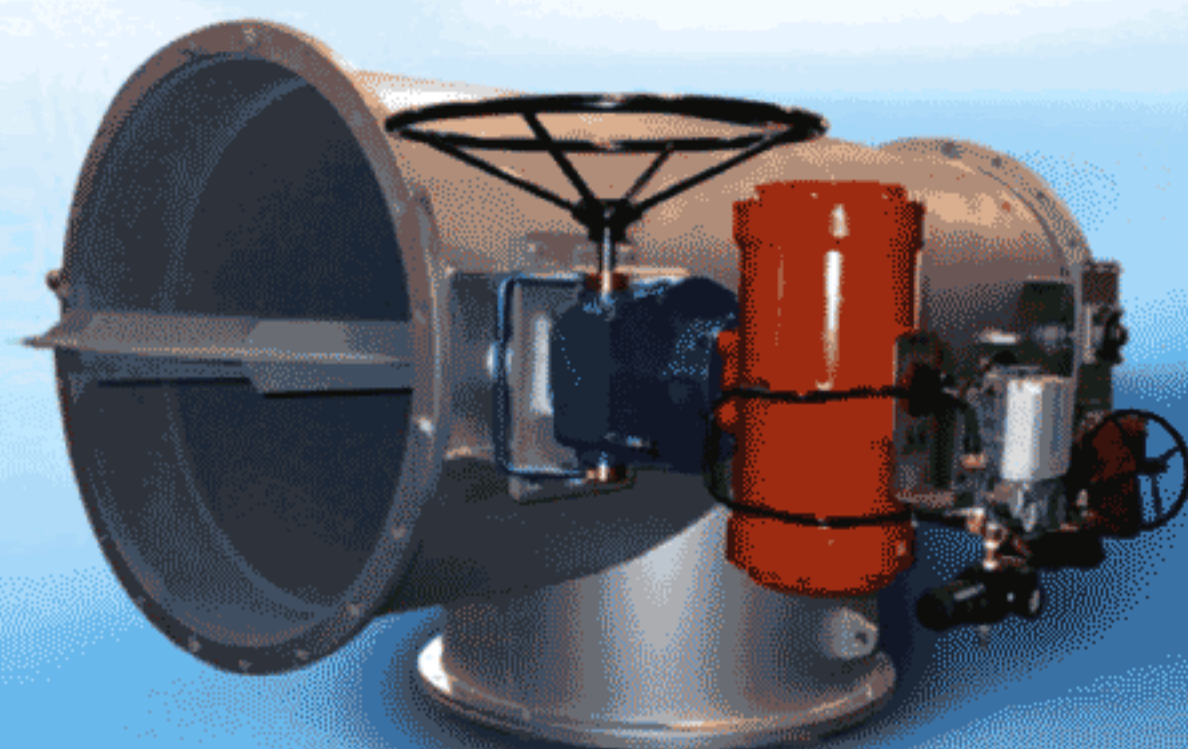
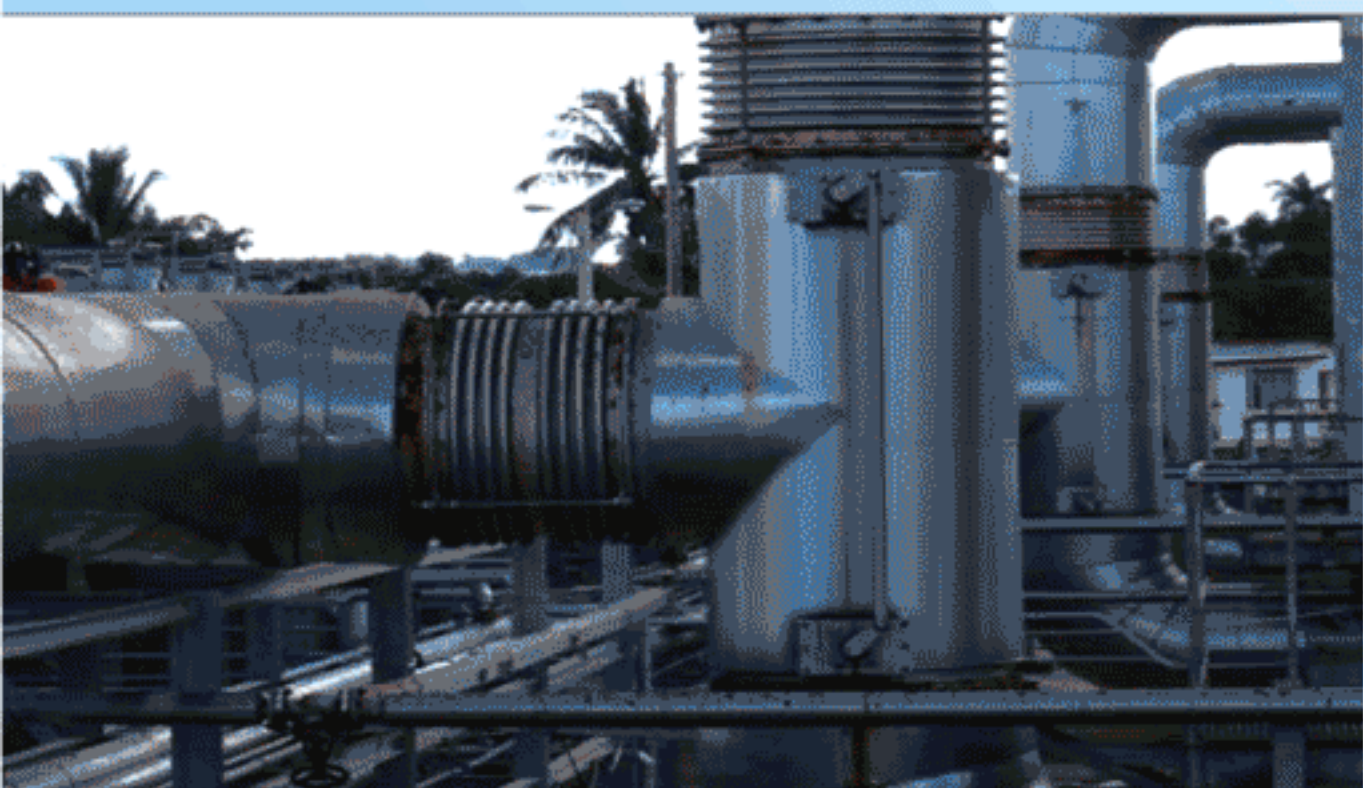

Figure 8-b

Part No.	Description	Part No.	Description	Part No.	Description	Part No.	Description
1	Housing	5	Electrical Actuator	9	Actuator Mounting Stand	13	Link Assly.
2	Flange	6	Stopper Bar	10	Hand Wheel	14	Mounting Skid
3	Flap	7	Bush	11	Stub End Shaft	15	Stuffing Box
4	Flap Seal	8	Bush Housing	12	Spring		



Poppet Dampers are ideal for applications that require quick cycling time and tight shut-off, poppet dampers provide isolation capabilities for bag house applications and incineration systems. Poppet dampers are used for multi-directional airflow control. They are engineered to control the reverse gas flow, outlet flow, and bypass flow of gases, in turn enhancing filtration, eliminating gas starving and reducing bag wear. (Refer figure 9 a & 9 b.)

Poppet Dampers provide economical shut-off capability for bag house applications.

Effox utilizes a standard design in the manufacture of this product, or the units can be custom manufactured to the client's specifications.

Poppet Dampers provide low cost shut-off in bag-house type collection systems. Low-leak or zero-leak configurations.



Figure 9 a : Poppet damper with Electrical Actuator



Figure 9 b : Poppet damper with Pneumatic Cylinder

Poppet Damper With Gas Flow Turning Means

Rectangular poppet damper or valve has particular utility as an isolation damper in fabric filter dust collector and includes integral gas flow turning means which are positioned so as to minimize pressure drop. The poppet plate is pivoted at one end to the floor of an inlet manifold and has a pair of gas straightening vanes attached to its underside. One of the vanes is near the pivoted end and the other is generally parallel to the poppet plate and has lead-in and exit portions which gently turn the gas about 90°. Where the gases are to be directed to a plurality of collectors, a damper is preferably provided for each, with the angles of the various poppet plates being individually adjustable so as to divide the flow in any proportion desired. Refer figure 9 c.

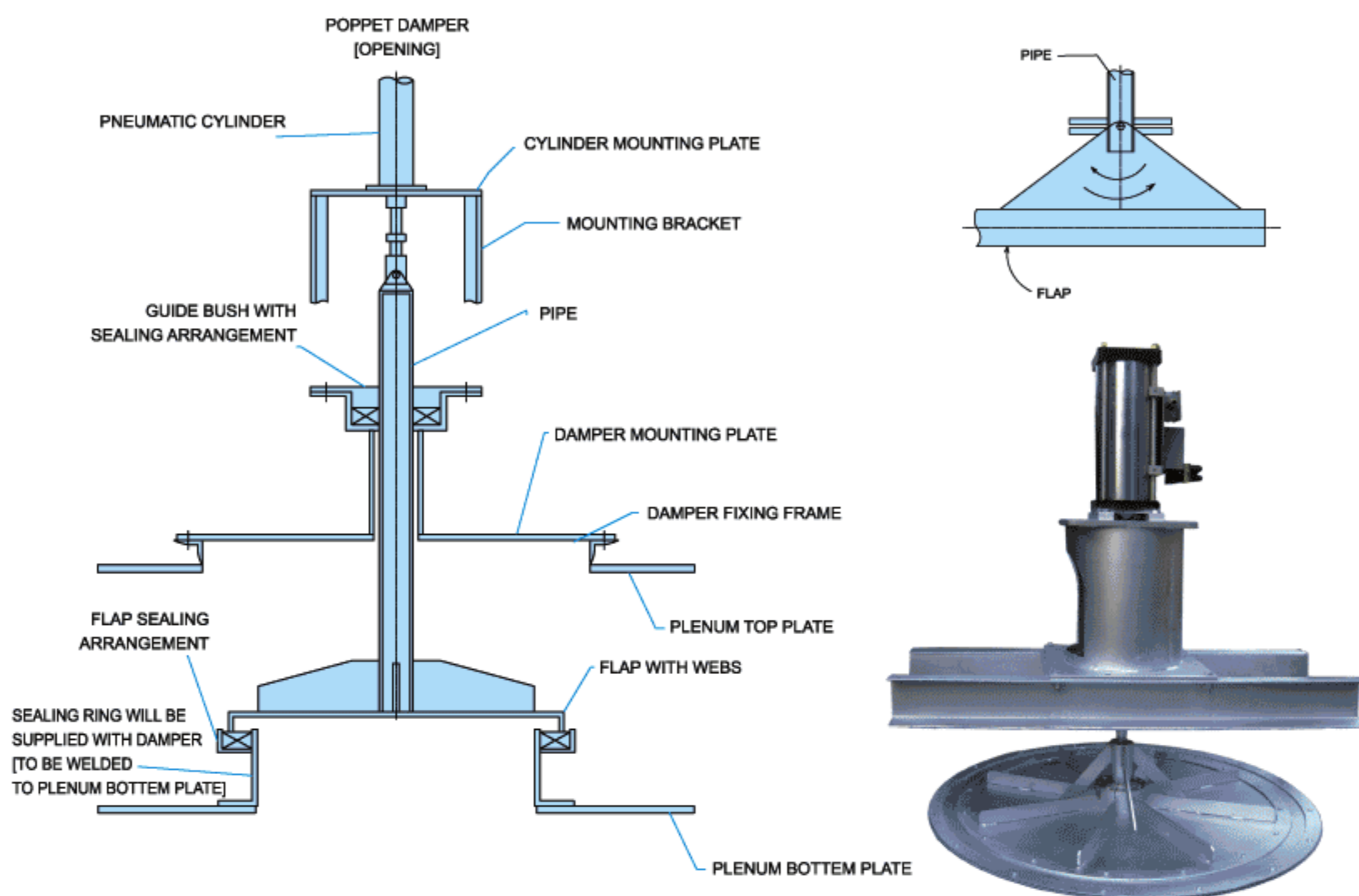

Figure 9 c : Block Diagram of Poppet damper

Ventilated Poppet Damper

A ventilated poppet damper assembly for use in a gas conveying conduit to selectively allow and prevent the flow of gas through the conduit has a movable pair of spaced apart damper plates which define a transverse chamber when in the closed position. The transverse chamber is vented to insure that there is no leakage of conveyed gas past the closed damper plates.

Description:

Sude manufactures a complete line of poppet dampers. The poppet is used on inlets, outlets and bypasses of certain bag house designs. Sude can provide our poppet dampers in sections or completely assembled. Some bag house manufacturers do not require the complete poppet assembly.

Sude can supply the poppet discs, seat and air cylinders for mounting into the manufacturers duct work.

- Sude poppet have several design features that make them superior to the design of many of their competitors. They provide a seat ring with either a Blanchard ground or a machined sealing surface. Their poppet disc has the ability to accept misalignments before final seating. These features provide for a better sealing poppet.
- Sude's standard shafts are made of 316 stainless steel, for providing corrosion resistance.
- Sude also manufactures a couple poppet designs, which can be used for bypass applications. The poppet consists of two discs fixed to the same shaft. A purge or a vacuum can be supplied to ensure a zero leak condition.

Stack Dampers are used for weather protection of the stack but also have added benefit of heat retention within the boiler. All large units incorporate "pressure relief" facilities to avoid dead ending the systems.

Data Sheet for Stack Dampers

- Damper Configuration : Single Louver, Twin Louver, Twin Flap
- Duct Size : 1.0m² to in excess of 60.0m²
- Temp. Range : -30°C up to +500°C, higher temp on request
- Seal Design : Seal ledge, Single flexible element, Twin flexible element (Un-pressurized & 100%)
- Materials : Mild steel, IS2062, IS2002, or any other Other material based on the requirements.
- Bearing Type : Non-lubricated ball bearing
- Shaft Design : Complete span
- Gland Assembly : Adjustable packed, Stuffing box type
- Operation : Open – Close, Electric, Pneumatic, Hydraulic
- Additions : Limit switches, Electrical wiring, Pressure relief
- Painting : All specifications

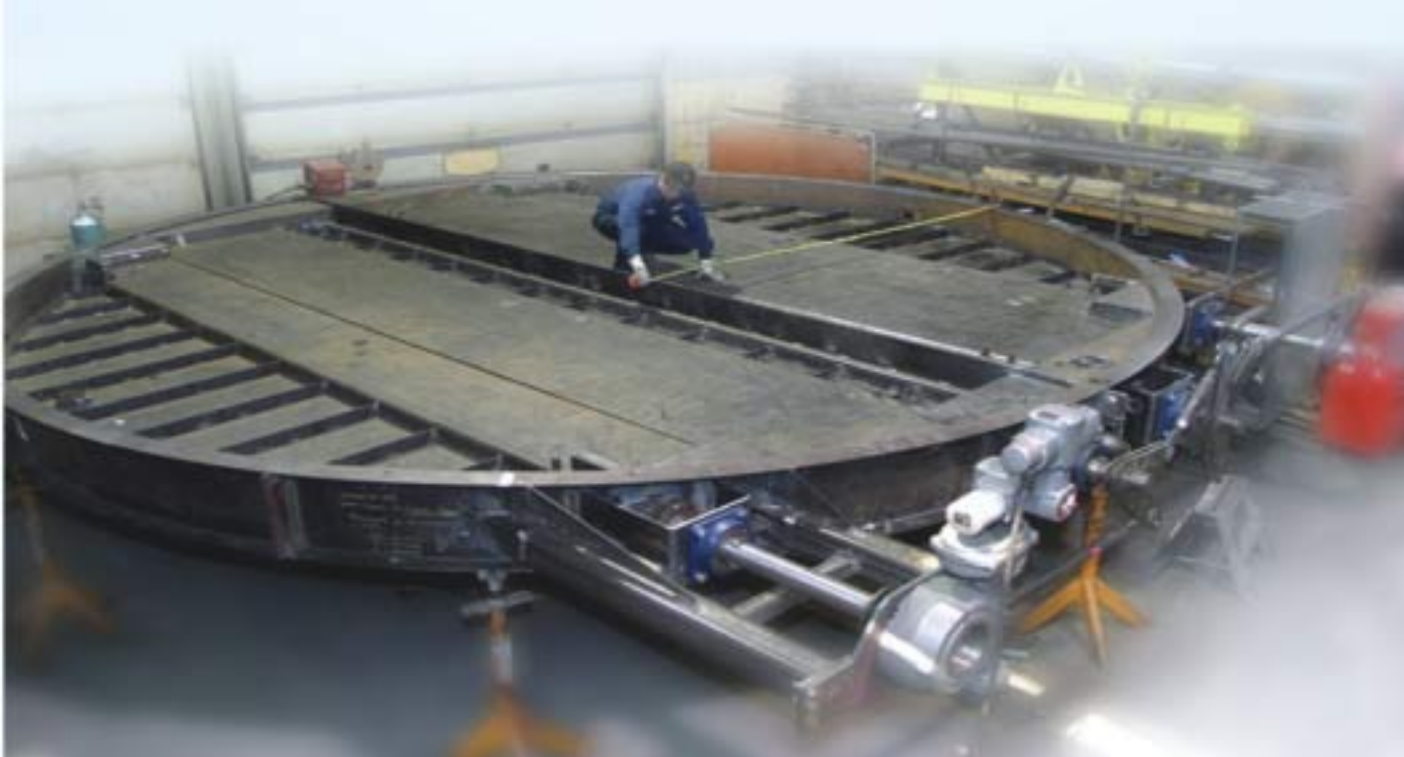
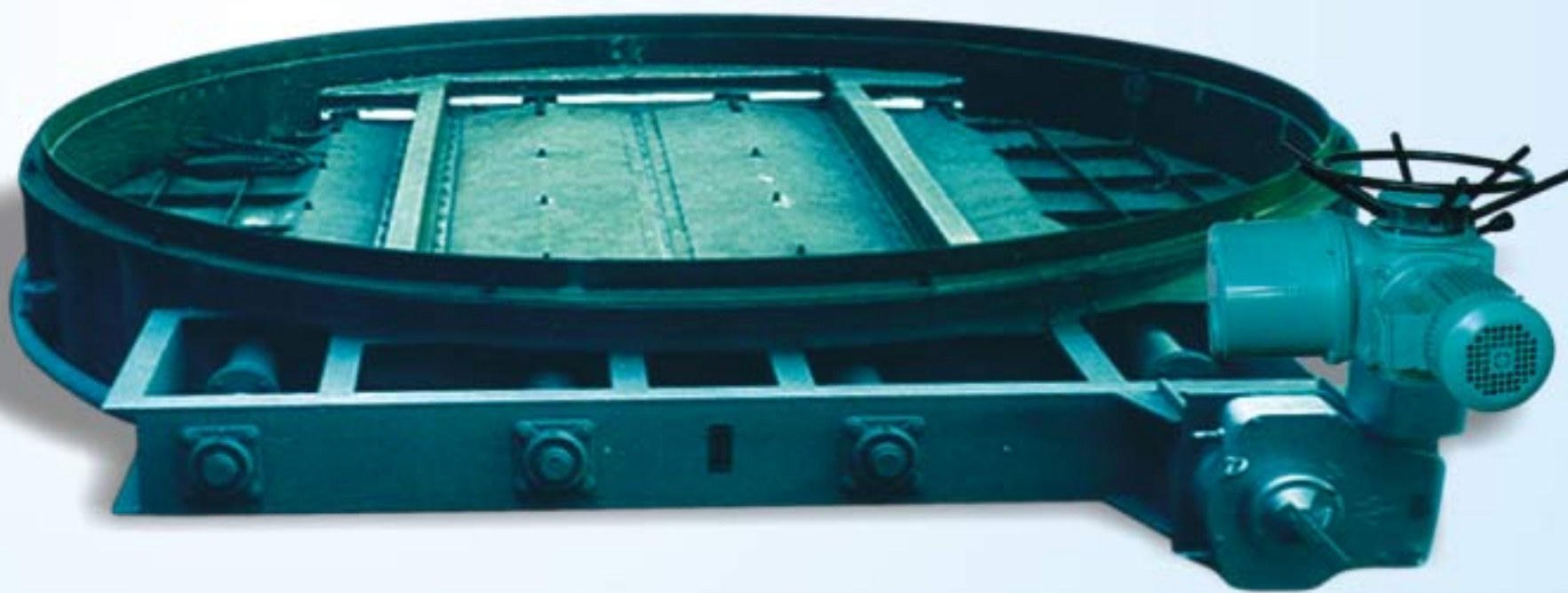

Stack dampers are used in conjunction with Heat recovery steam generation units and the primary function is to contain the temperature within the exhaust stack. Our design allows for pressure relief and has blades, which can be counter weighted for ease of motion.

Flange bearings with three-ring packing gland assembly are a standard and design for ease of service. Factors for thermal expansion are accounted for in blade design. Insulated blades and rain gutter are some of the options to consider.

Stack Isolation Dampers

STACK ISOLATION DAMPERS are used to protect the exhaust system from the elements and reduce the stack effect when the system is off line. The design can be equipped with adjustable counter balances for pressure relief applications.

The Stack Isolation Dampers can be provided in manageable size pieces to be installed in existing stacks.

Electric, pneumatic, hydraulic or manual actuation is available.

Stack Damper Control Arrangement

A stack damper control arrangement for use in a heating system including a furnace having a fuel-fired burner apparatus and a vent stack for conducting combustion products away from the burner apparatus and a damper plate pivotally mounted within the stack and movable between a fully open and a fully closed position, includes a reversible drive motor which is energized in response to a request for heat to drive the damper plate to the open position, a first limit switch operated when the damper plate reaches the open position to effect the de-energisation of the motor, the motor being re-energized at the end of the heating cycle to drive the damper plate to the closed position, and a second limit switch operated when the damper plate reaches the closed position to effect the de-energisation of the motor. The damper control arrangement is described with reference to a heating system including a gas fired burner and redundant gas valves wherein operation of a first one of the gas valves is effected through operation of the first limit switch and thus is conditional upon the damper being fully open, and wherein the supply of fuel to the second valve is conditional upon the operation of the first valve.

Stack Weather Protection Dampers

To minimize heat loss from the boiler and to prevent the ingress of rain water, Damper Technology have a range of stack isolating dampers which are designed for use with stacks from 300mm diameter to in excess of 7mt diameter.

The stack isolating damper can be of the butterfly, twin louver, multi-louver or twin flap design and can incorporate an automatic pressure relieving system to prevent over pressurization and damage to the turbine.



Fire Dampers are used to prevent transmission of flame where air ducts penetrate fire barriers. A fire barrier is a fire-resistant-rated vertical or horizontal assembly of materials designed to restrict the spread of fire in which openings are protected. They can also be employed in air transfer openings in walls and partitions. Building codes specify where fire dampers are required. Fire dampers are available in two types, static fire dampers and dynamic fire dampers.

Fire Dampers for Use in Static Systems, as their name implies, are used in duct systems or penetrations where there is no or negligible airflow when the damper closes. Fire Dampers for Use in Dynamic Systems are required at locations in which fan pressure will be on during a fire incident, and are expected to be able to operate (close) against the air velocity and pressure produced by the system fan. Refer figures 10 a, 10 b, 10 c.

Fire Damper **Product Range**



Figure 10 a : Fire Damper with quartz bulb



Figure 10 b : Fire Damper with Glass wool

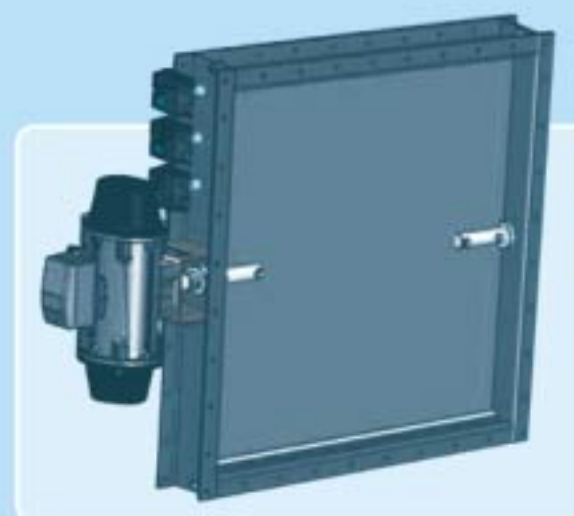

Figure 10 c : Pneumatic Operated Fire Damper



Both fire dampers for use in dynamic and static systems carry an hourly fire resistance rating, usually 1-1/2 or 3 hours. Fire dampers for use in dynamic systems are also provided with an airflow rating which indicates the maximum velocity and static pressure that the damper is designed for.

This type is used to protect a duct space or area against fire escape. There are two principal types, either the curtain type, which will snap shut upon receiving a signal (then requiring manually resetting), or the motorized type that can be opened or shut by use of an actuator. They normally have a minimum 4 hour fire rating.

Resistance to Airflow

The fire damper has a negligible resistance to airflow, as they open fully in the air stream. We can provide actual figures upon request, based upon air velocity. The gravity flap damper has an increased resistance to its mode of operating and, again, we can provide details of this upon request.

Application:

Fire Dampers are provided on air / gas ducts to control flow under normal circumstances and to isolate areas connected by duct from the fire affected area.

Construction:

Dampers are manufactured with single flap / multi-louvers. The louvers are connected through suitable linkage to a controlling actuating device, such as **electrical actuator / pneumatic spring return actuator / fusible link and more popular through solenoid**. Louver / flap shaft are provided with bearings having greasing facility to enable smooth rotation.

Louvers / flaps are made of mild steel. The louvers / flaps are designed in the form of a box and are sandwiched with high grade insulating material like glass wool which can withstand **980°C for period of 90 minutes**, thereby acting as effective barrier in closed position to the flame path between air duct and fire effected area.

The shape of the louver / flap is somewhat complex in nature for multifold purposes:-

- a) The complex shape reduces the leakage factor considerably.
- b) Fire exposed surfaces are backed-up by insulating material.
- c) Due to special insulating material, the strength of the louver / flap is retained at high temperature, thereby reducing the possibility of leakages.
- d) The shape provided, enables thermal expansion of the louver / flap without affecting sealing areas.

Positive Sealing Linkage:

Linkage provided with spring return device for positive shut-off pressure on each louver / flap, enabling reduction in leakage factor.

Sealing System:

Z sections are provided at mating surfaces are designed to create a heavy pressure drip during leakage, because the air / gas has to take two sharp right angle turns. This gives a low leakage factor during damper operation.

Sealing Efficiency:

The sealing efficiency of damper is 98% approximately on cross sectional area.

Closing Reliability:

Fire Dampers are designed to close automatically immediately (depend on mode of actuation, but in any case, not exceeding 60 seconds or fire effected area temperature reaches 141°C) on receive of Sensor's Signal of fire occurrence

Fire Dampers are used to prevent transmission of flame where air ducts penetrate fire barriers. A fire barrier is a fire-resistant-rated vertical or horizontal assembly of materials designed to restrict the spread of fire in which openings are protected. They can also be employed in air transfer openings in walls and partitions. Building codes specify where fire dampers are required.

Note:

Fire damper provided with Solenoid, damper will be closed from normal open condition automatically, either on receiving fire signals from sensor/detector, in case of fire or in case of power failure. On restoration of power supply, the damper will automatically be opened.

- For periodical testing, damper can be remotely controlled / operated for open/ close, without manual latching at site in such case they are supplied with spring return Pneumatic or Electric actuator.

Feature

Guillotine dampers are typically specified for heavy-duty and, gas tight shut-off of duct. Their design permits them to be installed into a short length of ductwork. Pressure drop is low across the wide-open damper. Guillotine blades are also better able to withstand furnace puffs and mild over pressure conditions than some other damper design. Guillotine performance needs can vary from a simple chain fall blanking plate design to fully automated 100% gas-tight perfect guillotine.

Blade Design

The damper blade is reinforced to minimize deflection and stress. Guillotine blades are protected from weather and to prevent gas from leaking into the atmosphere. We design and supply simple blades, structural blades, thermally compensating blades, and profiled blades. We will provide maximal resistance to heat stresses, corrosion, metal fatigue and distortion. When an application of heat retention is necessary, blades can be insulated. For high pressure or high temperature requirements, inspection port and view port for high dust loading applications as well as insulated blades for applications where heat retention or protections from thermal distortion are necessary.

Sealing System

The damper blades are designed with metal-metal or elastic seat systems. Flatness and strict manufacturing ensure optimal sealing in the installation. Guillotine can be supplied with a simple tadpole seal for 99% over sealing efficiency on the cross section. For applications needing 100% sealing efficiency, we applied seal air fans, fully enclosed bonnets and pressurized seals.

Drive System

Our guillotine damper is a proven and robust rack & pinion design, compared to older designs such as chains. The rack & pinion design is competitive in terms of cost, but far superior in terms of reliability. The design of driving guillotines is depending on the application. The entire actuator system of a guillotine damper shall be externally mounted and can be inspected and maintained while the main plant is running. We applied wide range of drive option from simple mounted pneumatic actuation to heavy-duty electric and hydraulic actuation with safety factor. Normally this safety factors are applied 3 times the calculated dead load plus 2 times live load force.



Dual Blade Guillotine

FEATURES

Description	Remarks
Dual Blade (Structural Blade) Isolation Guillotine Damper	99.9%
Electric Actuator (Explosion Proof) with 48:1 Gearbox unig	SDTORK
Installed Hot acid mixing gas solution combined with louver	Isolation & Control
Heavy-Duty Rack & Pinion drive unit with leakless stuffing box	
Operating time shall be 52 sec. maximum (Full Open-Close)	
Able to 100% isolation with seal air solution (enclosure box type)	

Guillotine Dampers provide man-safe isolation of ductwork and equipment. Low-leak structural seal design and zero-leak bellow seal design – rectangular or round geometry.

Sealing Arrangement to achieve 99.9 % - 100 % Sealing Efficiency

Flap Sliding Direction	Stuffing box with Bolted Gland & Gland Packing Location Stuffing Box Housing Gland Packing Material Duty	Flap Sliding Opening Welded to Housing Bolted Type for Packing Pressure 25 Sq. ABS or Glass Fiber To avoid Leakage from Openings
Flap Opening Direction	Location	Stuffing box
Sealing Chamber	Seal Seal Support	0.5 Thick. SS316 Specially Design Tung type. note - Two rows of Seals will be provided To hold the Tung type Seal in required position Seal supports provided.
Damper Flap Sealing Along the Length	Seal Seal Support Location Flap Edge	0.5 Thick. SS316 Specially Design Tung type. To hold the Tung type Seal in required position Seal supports provided. Welded to Housing Along the Length on opposite direction 100 mm. inside in Tung type Seal
Along the Width	Seal Seal Support Location Flap Edge	0.5 Thick. SS316 Specially Design Tung type. To hold the Tung type Seal in required position Seal supports provided. Welded to Housing Along the Length on opposite direction 100 mm. inside in Tung type Seal
Result	By providing the Specially Designed Tung type Seal to the Flap width & Length along with Stuffing box assembly at Flap Opening Direction we can achieve 99.9% to 100 % Sealing Efficiency.	

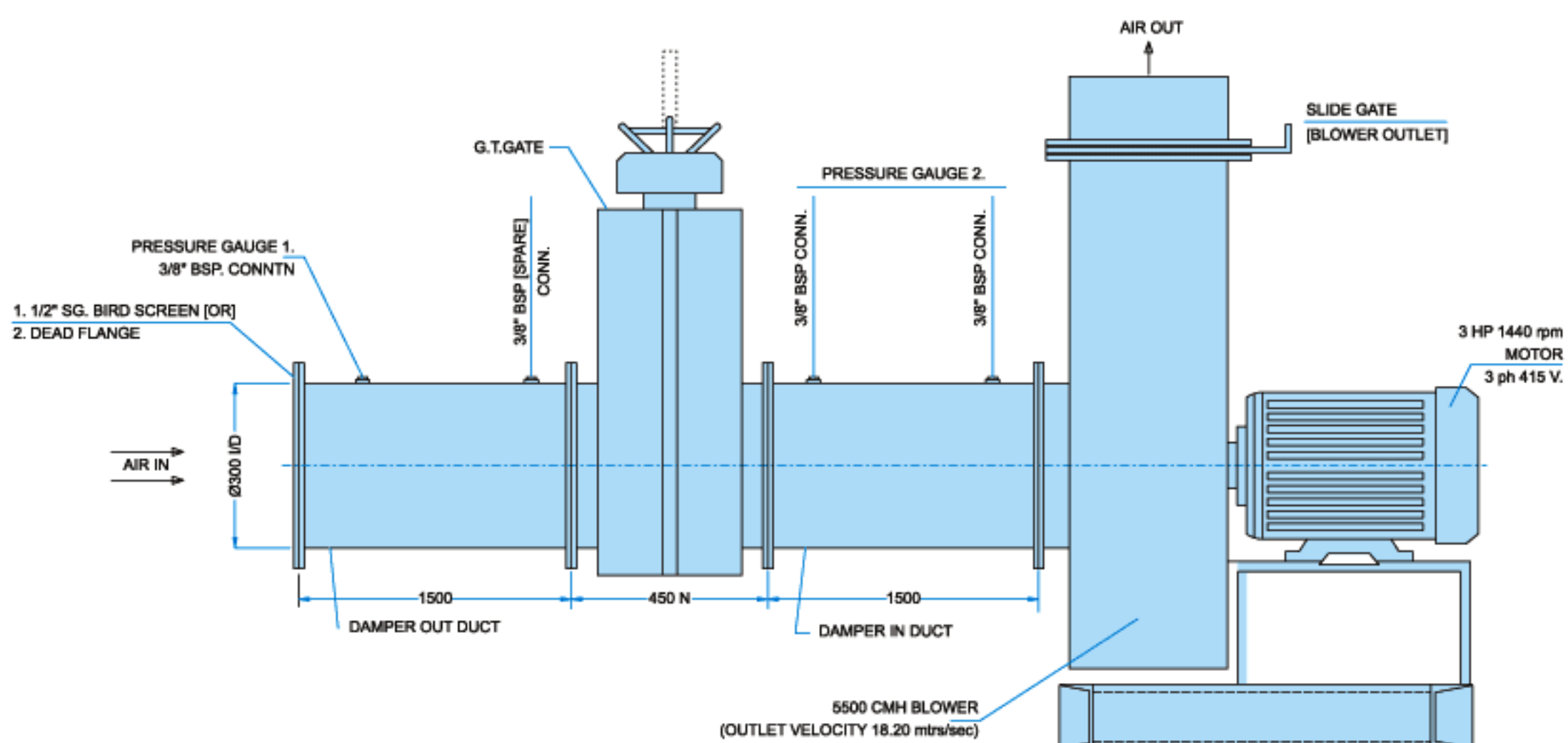

Figure 11 a : Test Bench for Guillotine Damper Efficiency Check.



Flap Gate with Pneumatic Cylinder



Flap Gate with Counter Weight

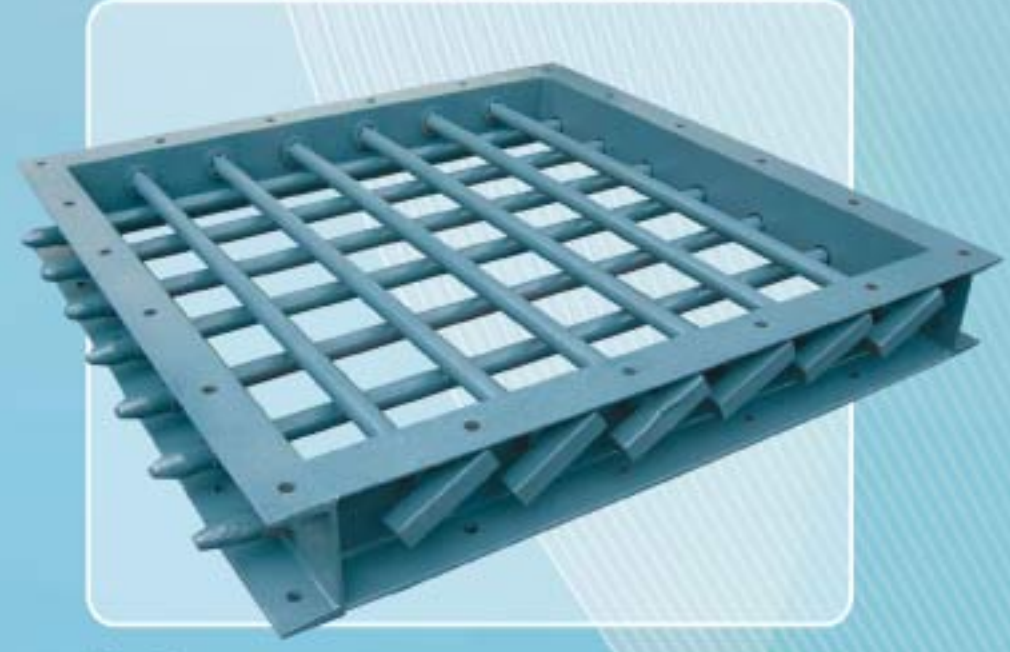

Pin Gate



Flap Gate with refractory lining



Slide Gates



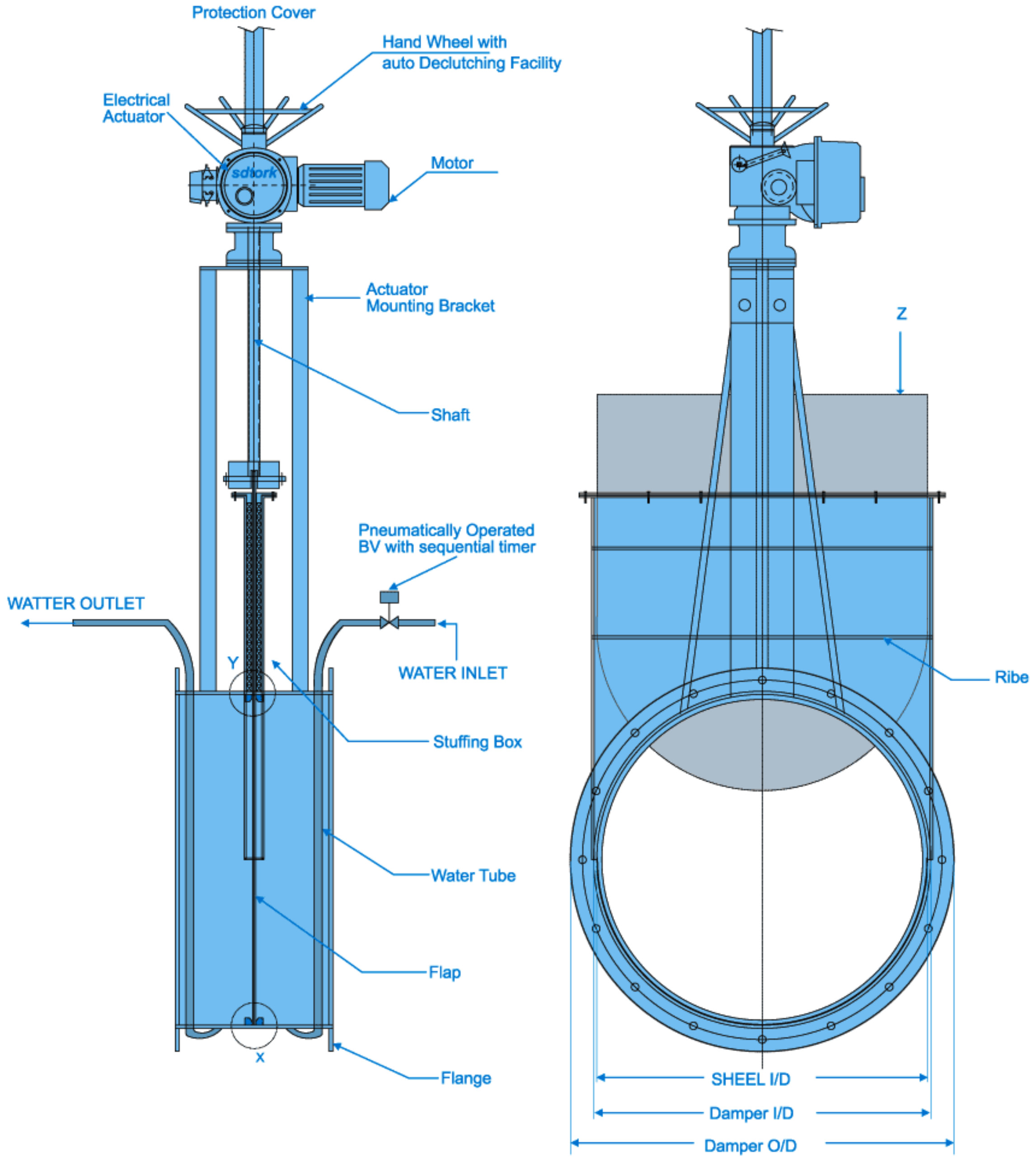

X - Sealing Details

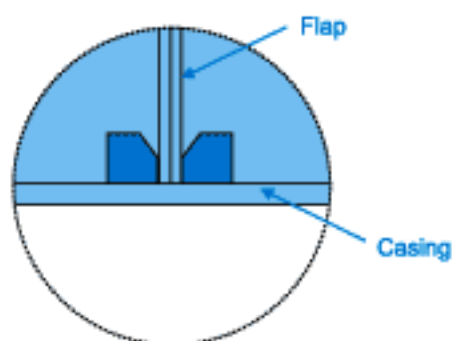

Y - Stuffing Box Details

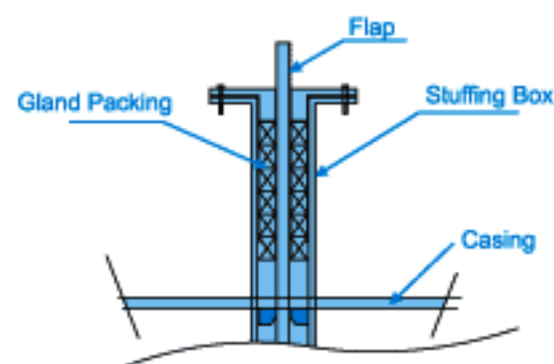

Z - Top View of Stuffing Box

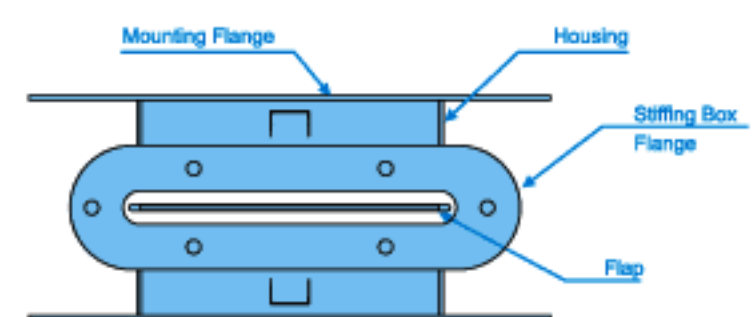

Comparison Features And General Comments Of Different Dampers Along with It's Functioning:

Dampers regulate the volume flow of radial fans to adapt the fans to the different operating conditions of a plant.

The alteration of flow with the help of dampers is an inexpensive but rather energy-consuming method of control. Inlet guide vanes prove to be much more reasonable. The shape of the adjustable guiding vanes reduces the impact loss, which results from guiding the air flow on entering the impeller.

In the direction of flow, dampers are not entirely airtight when closed. The corresponding rate of leak depends on the number of blades, the gap area and the pressure applied. The leak rate can be reduced by overlapping the guiding vanes. Inlet guide vanes with a nominal diameter of less than 900 mm have no central support and therefore are open in the middle.

All dampers are constructed according to the operating conditions known to us.

In general, the shafts of the vanes run in sleeve bearings. These bearings offer a wide range of application; their advantages are low friction coefficient, high chemical stability and an extensive range of operable temperature.

Thanks to an aerodynamic design of the central support, the guiding blade of inlet guide vanes from nominal diameter size 900 mm onwards is supported in two places. The consequent relief of the main bearing leads to an extended service life of the bearing in general and reduces the actuating power. Maintenance-free ball-and-socket joints and angle joints serve for power transmission on the individual shafts free from float. Misalignments which might occur due to tolerances in construction and varying thermal expansions are thus compensated and a continuous smooth running is guaranteed.

A supporting structure is offered for inlet guide vanes from nominal diameter 800 mm onwards which is meant to reduce stress on the inlet. The problem of different vibration behavior of inlet guide vane and fan is solved by mounting the support on the fan housing. If the power transmission from actuator to inlet guide vane should be executed by an actuating leverage a supporting structure will be necessary.

Dampers shall have either a galvanized steel casing of all welded corner construction and having peripheral flanges pre-punched with elongated corner hole fixing to suit proprietary duct flanges or with spigotted adaptor plates to suit square, rectangular, circular or flat oval connections.

Manually operated dampers shall have quadrant control with visual blade position indication.

Damper suitable for systems requiring air control and very low closed blade leakage characteristics, suitable for high pressure and high velocity applications..

The outer flanges are normally supplied un-drilled unless otherwise requested and, where the louvers or dampers are suited externally, weather covers can be fitted over the spindle ends and motors for protection against prevailing weather conditions.

Parallel versus Opposed Blade Operation Control dampers are offered with either parallel or opposed blades. Each style has distinguishing characteristics in regards to control of the fan's performance plus a change in air velocity profile.

In applications where dampers are required to be installed in round or oval ductwork, they must be supplied with the appropriate transition option. Rectangular dampers are constructed 2 in. larger than the duct dimensions and provided with a factory sleeve. The sleeve is transitioned at each end to the appropriate round, oval or rectangular duct size.

Round damper frames are rolled from a single thickness of galvanized steel and reinforced as required for strength.

Manual balancing dampers are designed for use in balancing an HVAC duct system to achieve desired airflow at all locations. These dampers are then locked in position. Manual balancing dampers are designed only for control of airflow, not for tight shut-off.

Rectangular frames are designed for installation within a section of rectangular duct and round frames are designed to connect between two sections of round duct. Axles are square plated steel. Bearings are sleeve type.

Rectangular Dampers single (parallel and opposed) and double louver design allow “man-safe” isolation and precise flow control on precipitator, bag-house, scrubber and gas turbine fan inlet and outlets – round, square or rectangular configurations available.

Butterfly Dampers single and multi-blade designs provide low cost isolation and flow control of flue gases. Low-leak or man-safe designs available.

Diverter Dampers directs gas flow from gas turbine exhaust to heat recovery boiler or bypass system. Single flapper blade with unique Bellow seal design provides high (99.9%) sealing efficiency – man-safe design available with a temperature range to 1200°F.

Poppet Dampers provide low cost shut off in bag-house type collection systems. Low-leak or zero-leak configurations.

Maintenance

Like any mechanical device, dampers require periodic maintenance to ensure continued proper operation. The level of maintenance required is dependent on several factors including the product manufacture’s and system designer’s recommendations, code requirements, and the complexity of the system in which the damper is installed.

Periodic maintenance of dampers should include the following:

- Removal of debris buildup from the damper and surrounding area
- Manual cycling of dampers released by fusible links
- Cycling of damper and actuator assemblies.





Camboers



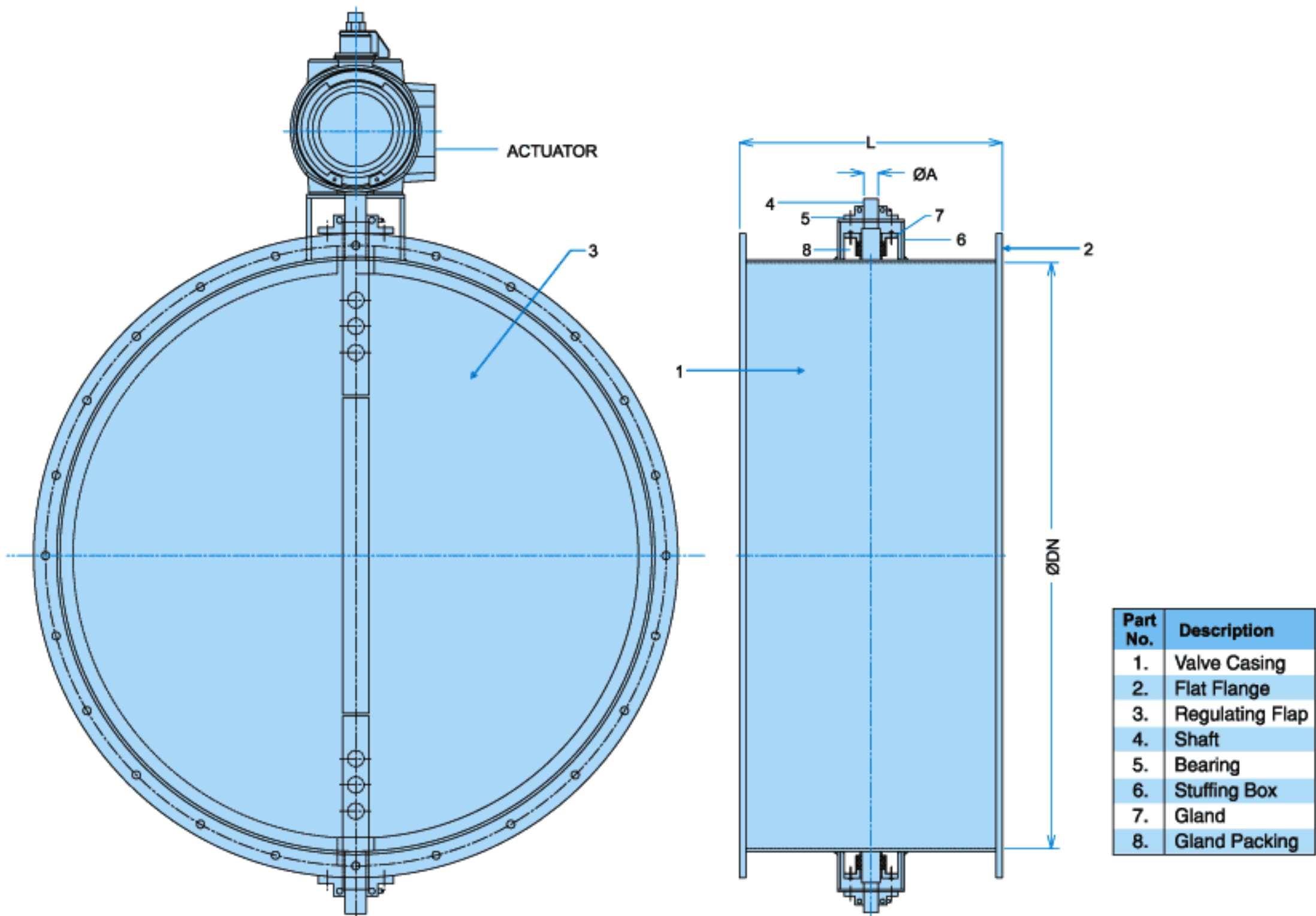

Part No.	Description
1.	Valve Casing
2.	Flat Flange
3.	Regulating Flap
4.	Shaft
5.	Bearing
6.	Stuffing Box
7.	Gland
8.	Gland Packing

Figure 12 a : Pneumatic Actuated Single Flap Round Butterfly Damper.

MODEL NO.	NOMINAL DIA		A in mm	NO. OF BLADES
	Ø DN in mm	L in mm		
1962BFDS / 100 / 3.15 / 40X6	100	225	15	1
1962BFDS / 150 / 3.15 / 40X6	150	225	15	1
1962BFDS / 200 / 3.15 / 40X6	200	225	15	1
1962BFDS / 250 / 3.15 / 40X6	250	250	15	1
1962BFDS / 300 / 3.15 / 40X6	300	250	20	1
1962BFDS / 350 / 3.15 / 40X6	350	250	20	1
1962BFDS / 400 / 3.15 / 40X6	400	315	20	1
1962BFDS / 450 / 3.15 / 40X6	450	315	20	1
1962BFDS / 500 / 3.15 / 40X6	500	315	25	1
1962BFDS / 550 / 3.15 / 40X6	550	400	25	1
1962BFDS / 600 / 3.15 / 40X6	600	400	25	1
1962BFDS / 650 / 3.15 / 40X6	650	400	20	1
1962BFDS / 700 / 3.15 / 40X6	700	450	30	1
1962BFDS / 750 / 3.15 / 40X6	750	450	30	1
1962BFDS / 800 / 3.15 / 40X6	800	450	30	1
1962BFDS / 850 / 3.15 / 40X6	850	450	30	1
1962BFDS / 900 / 3.15 / 40X6	900	450	30	1
1962BFDS / 950 / 3.15 / 40X6	950	225	30	1
1962BFDS / 1000 / 3.15 / 40X6	1000	225	30	1
1962BFDS / 1050 / 3.15 / 40X6	1050	225	30	1
1962BFDS / 1100 / 3.15 / 40X6	1100	250	30	1
1962BFDS / 1150 / 3.15 / 40X6	1150	250	30	1
1962BFDS / 1200 / 3.15 / 40X6	1200	250	35	1
1962BFDS / 1250 / 3.15 / 40X6	1250	315	35	1
1962BFDS / 1300 / 3.15 / 40X6	1300	315	35	1
1962BFDS / 1350 / 3.15 / 40X6	1350	315	35	1
1962BFDS / 1400 / 3.15 / 40X6	1400	400	35	1
1962BFDS / 1450 / 3.15 / 40X6	1450	400	35	1
1962BFDS / 1500 / 3.15 / 40X6	1500	400	35	1
1962BFDS / 1550 / 3.15 / 40X6	1550	450	35	1

Diverted Dampers

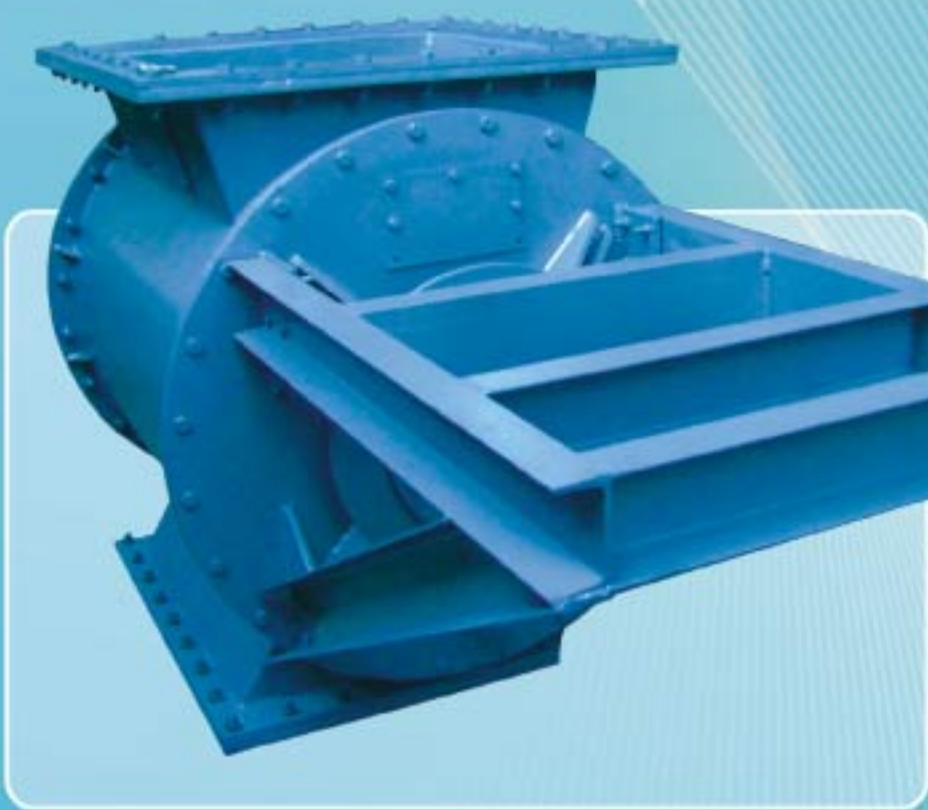

Rotary Air Sluice

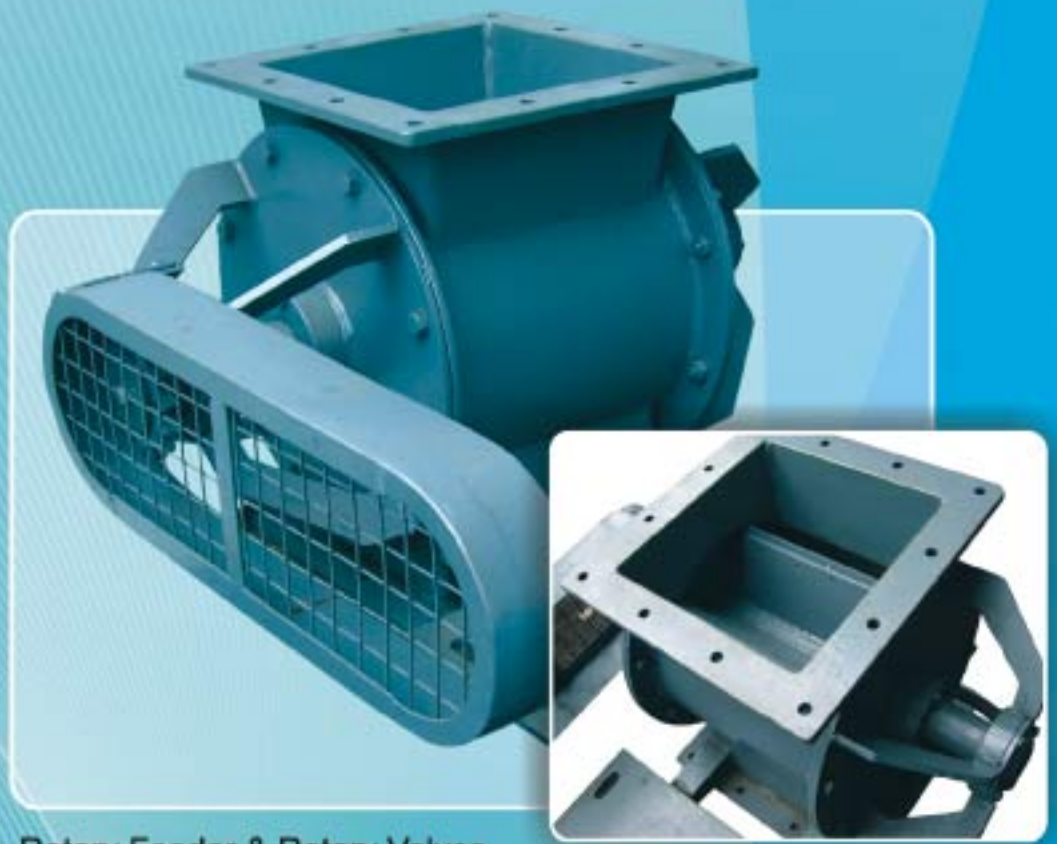

Rotary Feeder & Rotary Valves



Dampers

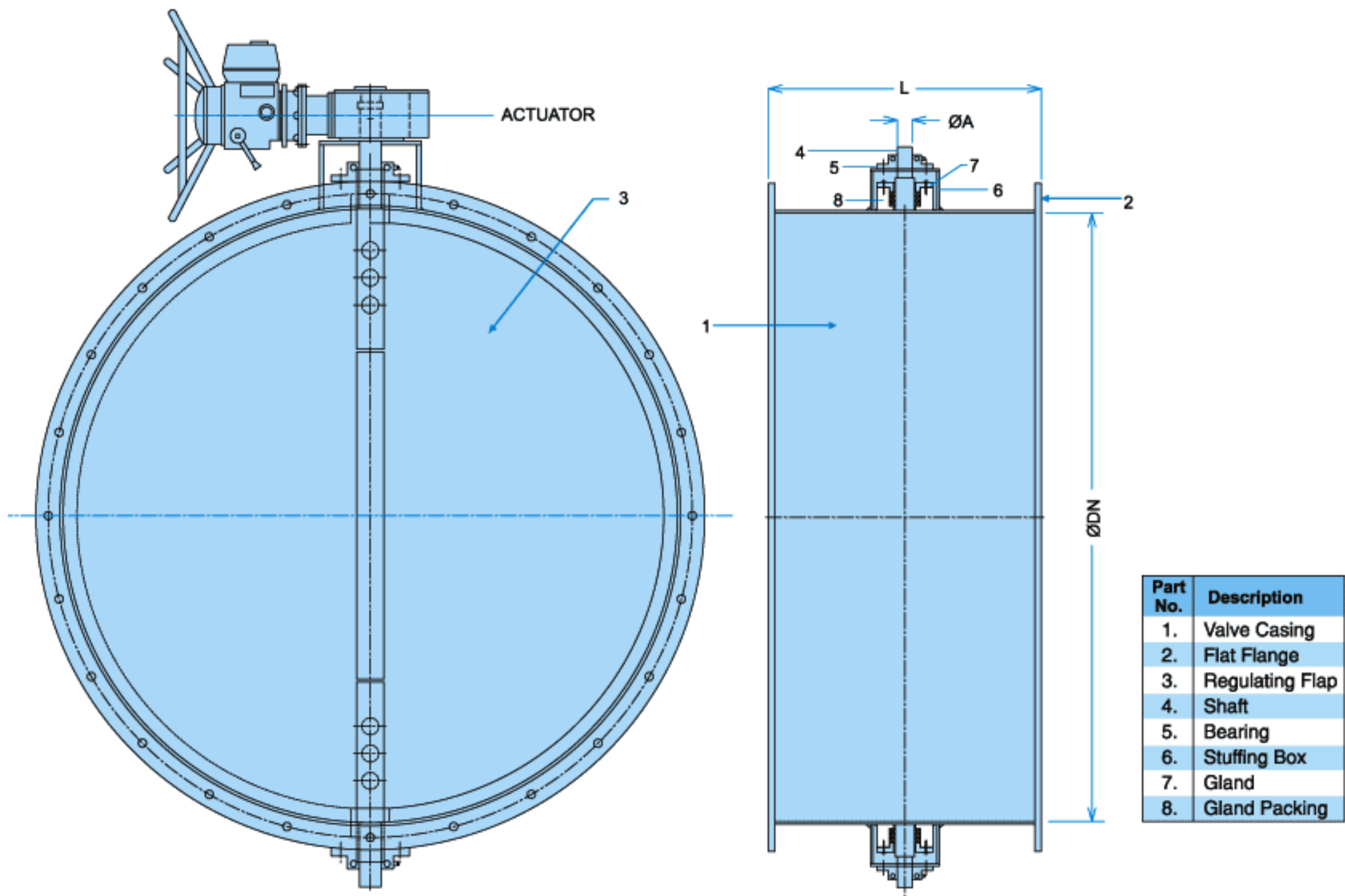

Part No.	Description
1.	Valve Casing
2.	Flat Flange
3.	Regulating Flap
4.	Shaft
5.	Bearing
6.	Stuffing Box
7.	Gland
8.	Gland Packing

Figure12 b : Electric Actuated Single Flap Round Butterfly Damper.

MODEL NO.	NOMINAL DIA		A in mm	NO. OF BLADES
	Ø DN in mm	L in mm		
1952BFDS / 100 / 3.15 / 40X6	100	225	15	1
1952BFDS / 150 / 3.15 / 40X6	150	225	15	1
1952BFDS / 200 / 3.15 / 40X6	200	225	15	1
1952BFDS / 250 / 3.15 / 40X6	250	250	15	1
1952BFDS / 300 / 3.15 / 40X6	300	250	20	1
1952BFDS / 350 / 3.15 / 40X6	350	250	20	1
1952BFDS / 400 / 3.15 / 40X6	400	31 5	20	1
1952BFDS / 450 / 3.15 / 40X6	450	31 5	20	1
1952BFDS / 500 / 3.15 / 40X6	500	31 5	25	1
1952BFDS / 550 / 3.15 / 40X6	550	400	25	1
1952BFDS / 600 / 3.15 / 40X6	600	400	25	1
1952BFDS / 650 / 3.15 / 40X6	650	400	20	1
1952BFDS / 700 / 3.15 / 40X6	700	450	30	1
1952BFDS / 750 / 3.15 / 40X6	750	450	30	1
1952BFDS / 800 / 3.15 / 40X6	800	450	30	1
1952BFDS / 850 / 3.15 / 40X6	850	450	30	1
1952BFDS / 900 / 3.15 / 40X6	900	450	30	1
1952BFDS / 950 / 3.15 / 40X6	950	225	30	1
1952BFDS / 1000 / 3.15 / 40X6	1000	225	30	1
1952BFDS / 1050 / 3.15 / 40X6	1050	225	30	1
1952BFDS / 1100 / 3.15 / 40X6	1100	250	30	1
1952BFDS / 1150 / 3.15 / 40X6	1150	250	30	1
1952BFDS / 1200 / 3.15 / 40X6	1200	250	35	1
1952BFDS / 1250 / 3.15 / 40X6	1250	315	35	1
1952BFDS / 1300 / 3.15 / 40X6	1300	315	35	1
1952BFDS / 1350 / 3.15 / 40X6	1350	315	35	1
1952BFDS / 1400 / 3.15 / 40X6	1400	400	35	1
1952BFDS / 1450 / 3.15 / 40X6	1450	400	35	1
1952BFDS / 1500 / 3.15 / 40X6	1500	400	35	1
1952BFDS / 1550 / 3.15 / 40X6	1550	450	35	1

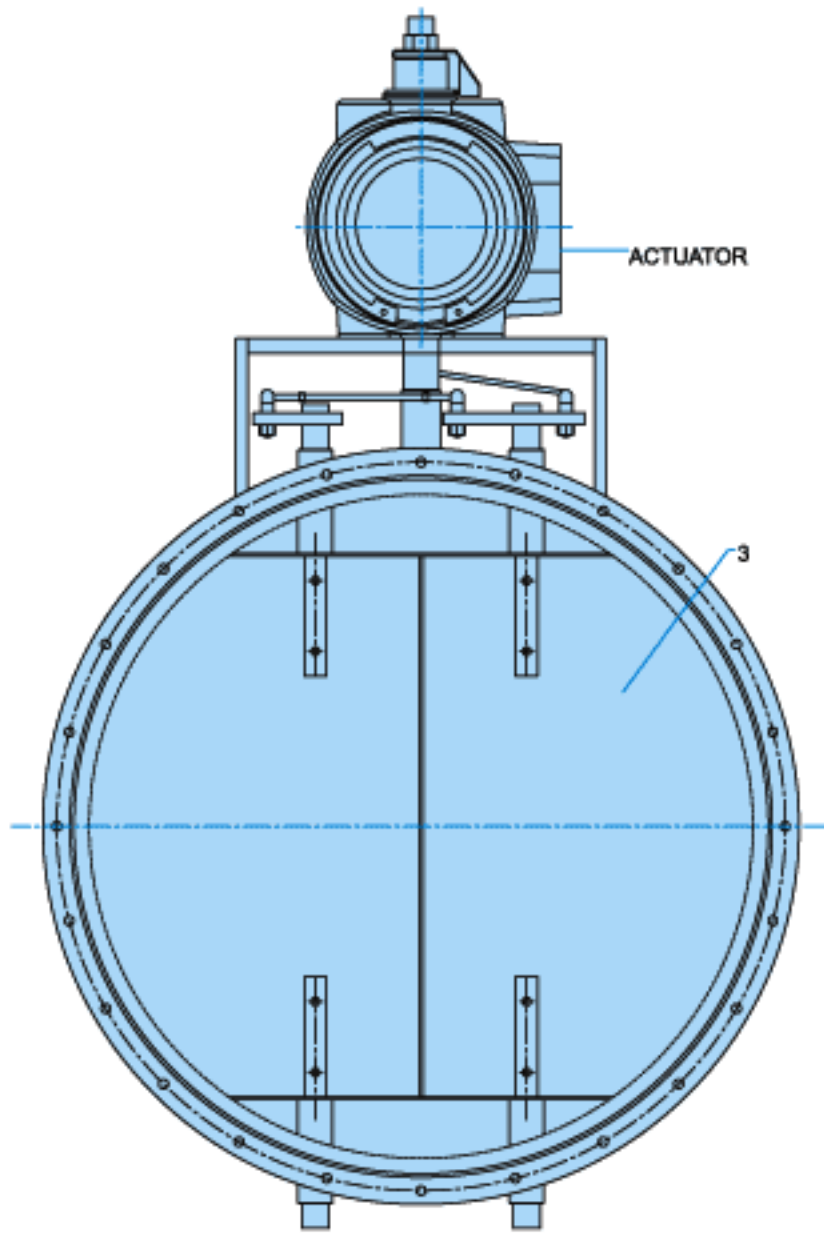

Figure 12 c : Pneumatic Actuated Double Flap Round Butterfly Damper

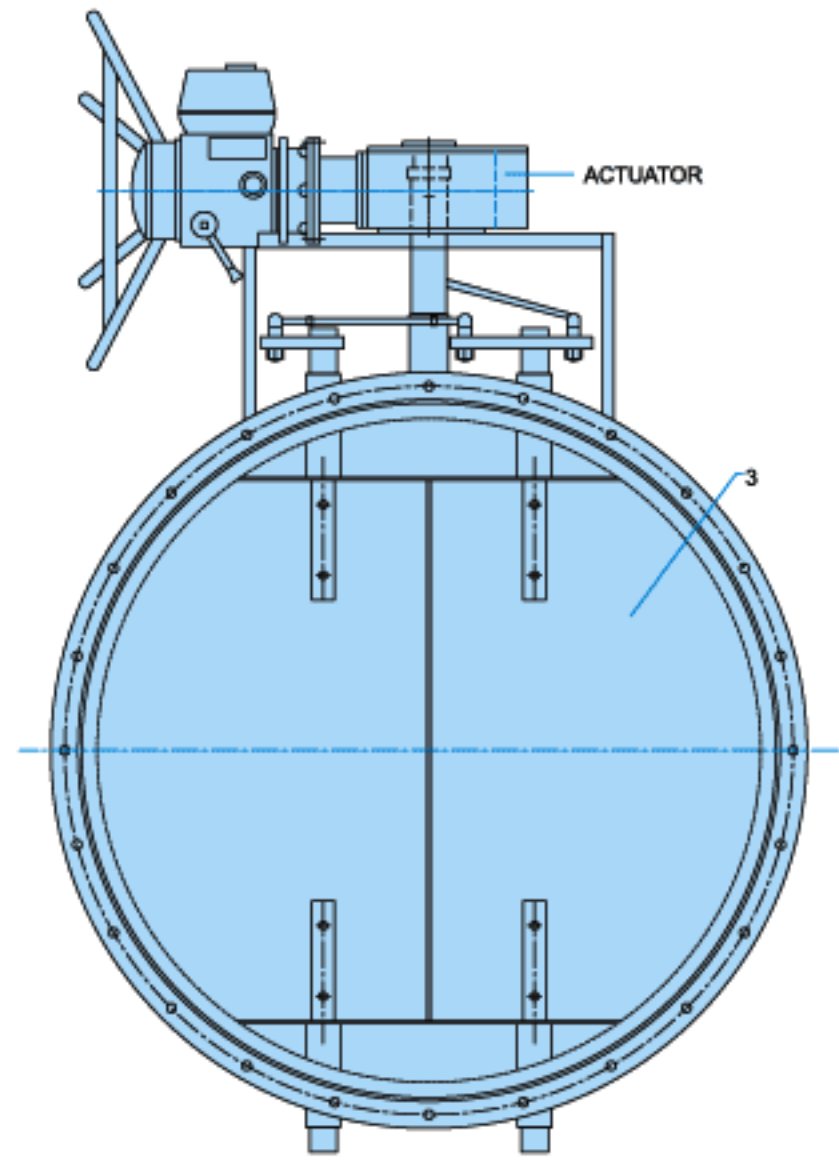
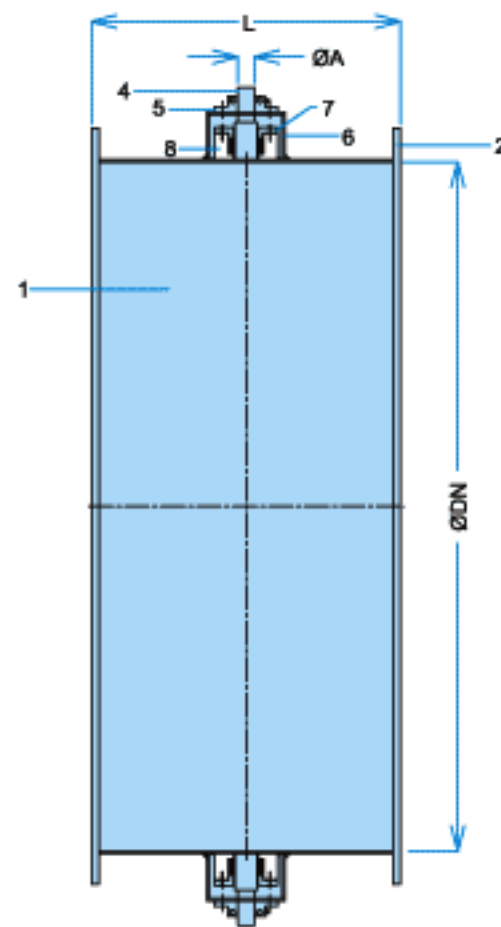

Figure 12 d : Electric Actuated Double Flap Round Butterfly Damper

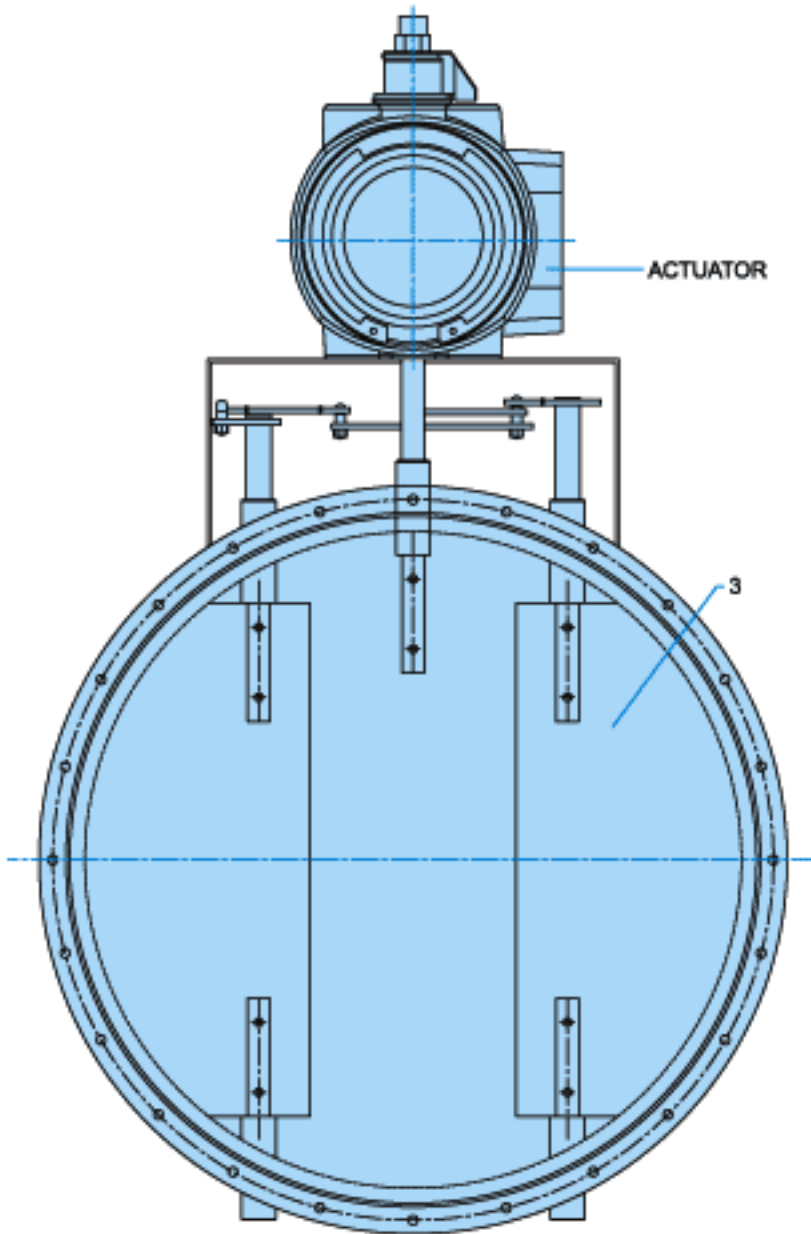

Figure -1 2 e : Pneumatic Actuated Three Flap Round Butterfly Damper.

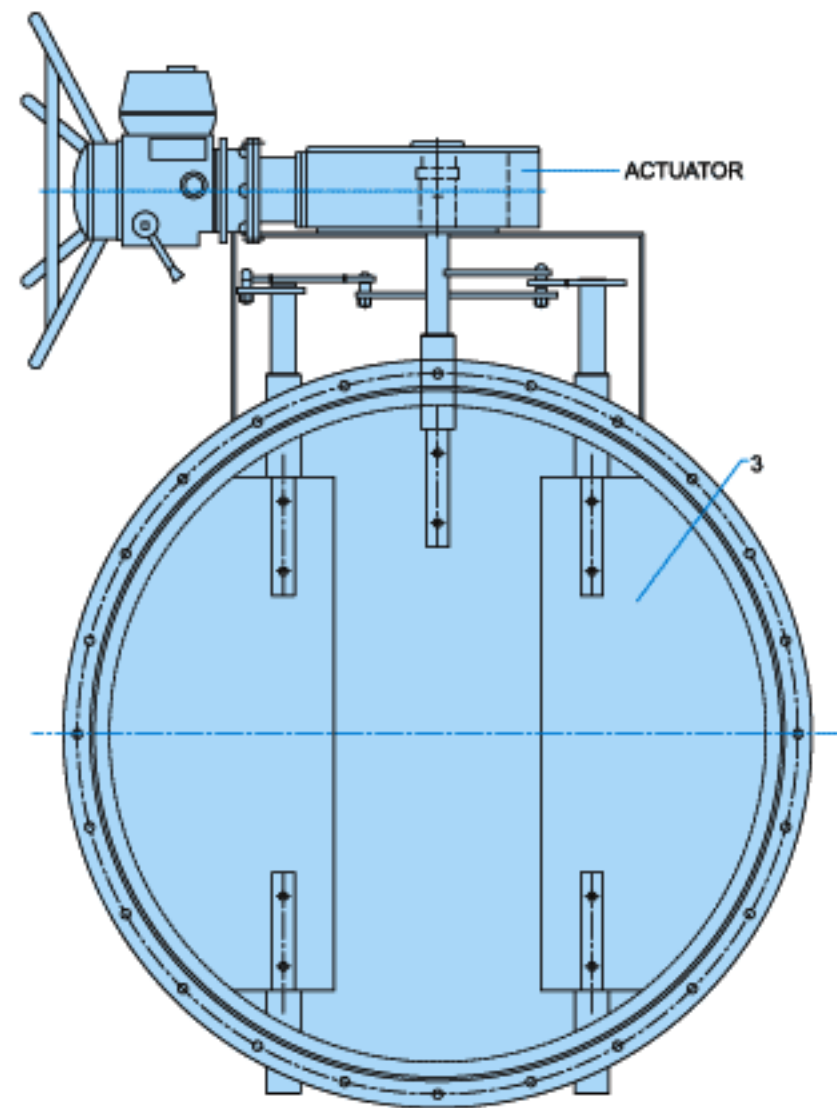
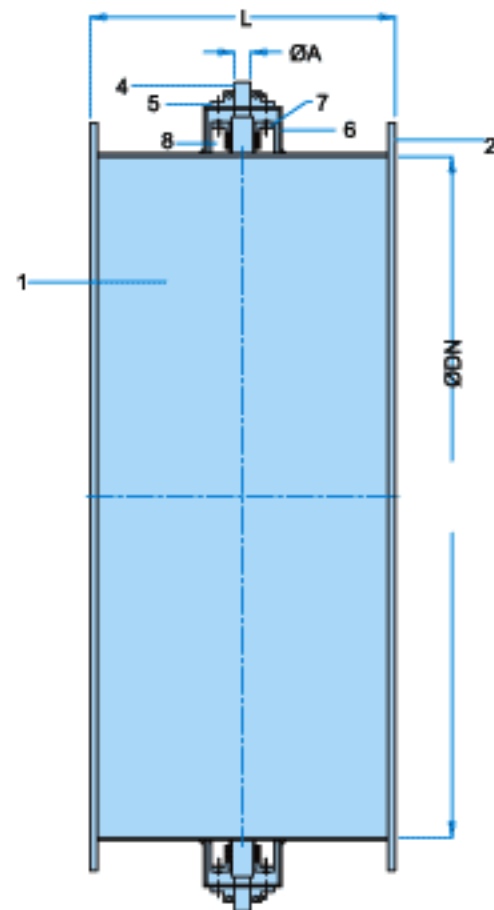

Figure 12 f : Electric Actuated Three Flap Round Butterfly Damper.

Note: The above dimensional drawing 12a, 12c & 12e is a round damper with Single flap, double flap, triple flap respectively fitted with Pneumatic actuators and 12b, 12d & 12f is a round damper with Single flap, double flap, triple flap respectively fitted with Motorized actuator. considering 40x6 flange with Body & Disc thickness of 3.15mm, for different dimension please obtain the fresh drawing from us. The dimensional drawing for single, double and triple flap they are almost same, for calculation purpose you can use the above given dimension however it is our suggestion to obtain the final drawing from us.

How to Order :

	Description	Model Number Creation
Type of Actuator	Pneumatic With model no.	1962 [P40]
Type of damper	Round Single flap	BFDS
Damper size	in mm	800
Damper Length	in mm	400
Body Material	Mild Steel	MS
Disc Material	Mild Steel	MS
Body thickness	in mm	3.15
Disc thickness	in mm	6.0
Flange details		50x8
Temperature	Maximum	300°C
Characteristic	Proportional	LNN
Leakage class	98%	98
Proximity switches	2 nos	2PS
Electro Pneumatic Positioner	Siemens make	SP
Position transmitter	4-20mA output	PT
FRL Unit	Shavo/Norgen Of ¼"	FRL

Hence the final model number under Pneumatic will be

1962BFDS / 800 / 400 / MS / MS / 3.15 / 6.0 / 50x8 / P40 / LNN / SB / 2PS / SP / PT / FRL

	Description	Model Number Creation
Type of Actuator	Motorized with model no.	1952 [SD-4000-20-WG60]
Type of damper	Round double flap	BFDD
Damper size	in mm	800
Damper Length	in mm	400
Body Material	Mild Steel	MS
Disc Material	Mild Steel	MS
Body thickness	in mm	6.0
Disc thickness	in mm	8.0
Flange details		50x8
Temperature	Maximum	300oC
Characteristic	Proportional	LNN
Leakage class	98%	98
Extra switches	2 nos	2AS
Electronic Positioner	with panel	WCP
Position transmitter	4-20mA output	PT

Hence the final model number under Motorized will be

1952BFDD / 800 / 400 / MS / MS / 6.0 / 8.0 / 50x8 / SD - 4000 - 20 - WG60 / LNN / 98 / 2AS / WCP / PT

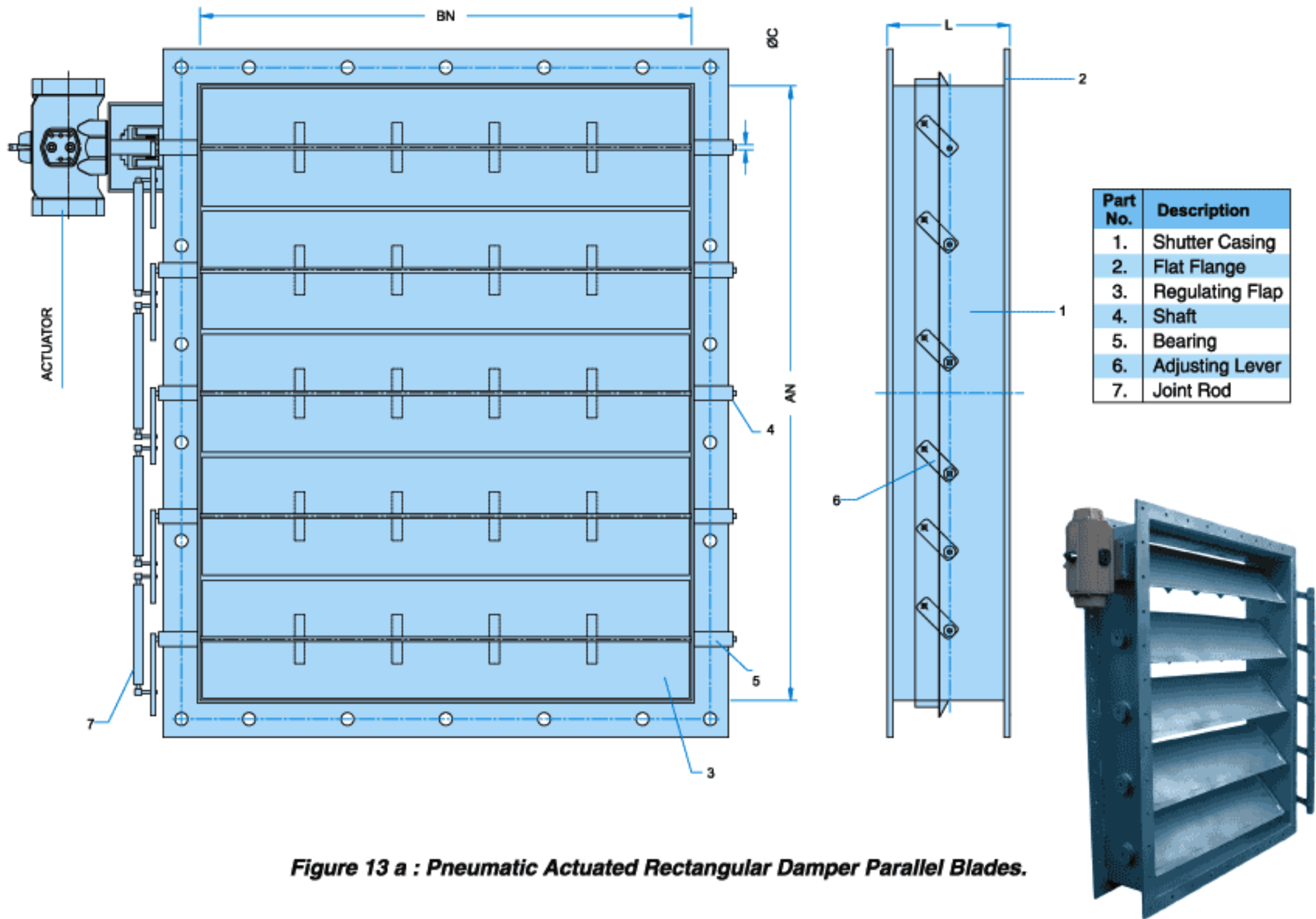

Figure 13 a : Pneumatic Actuated Rectangular Damper Parallel Blades.

MODEL NO.	NOMINAL SIZE		L in mm	C in mm	NO. OF BLADES
	AN in mm	BN in mm			
1962RD / 100 / 3.15 / 40X6	100	125	140	15	1
1962RD / 150 / 3.15 / 40X6	150	125	140	15	1
1962RD / 200 / 3.15 / 40X6	200	160	200	15	1
1962RD / 250 / 3.15 / 40X6	250	200	250	15	1
1962RD / 300 / 3.15 / 40X6	300	250	180	20	2
1962RD / 350 / 3.15 / 40X6	350	280	180	20	2
1962RD / 400 / 3.15 / 40X6	400	315	200	20	2
1962RD / 450 / 3.15 / 40X6	450	335	225	20	2
1962RD / 500 / 3.15 / 40X6	500	400	250	20	2
1962RD / 550 / 3.15 / 40X6	550	450	200	25	3
1962RD / 600 / 3.15 / 40X6	600	500	225	25	3
1962RD / 650 / 3.15 / 40X6	650	500	225	25	3
1962RD / 700 / 3.15 / 40X6	700	560	250	25	3
1962RD / 750 / 3.15 / 40X6	750	600	280	20	3
1962RD / 800 / 3.15 / 40X6	800	630	200	20	4
1962RD / 850 / 3.15 / 40X6	850	630	200	25	4
1962RD / 900 / 3.15 / 40X6	900	710	225	25	4
1962RD / 950 / 3.15 / 40X6	950	710	225	25	4
1962RD / 1000 / 3.15 / 40X6	1000	800	250	25	4
1962RD / 1050 / 3.15 / 40X6	1050	800	250	30	4
1962RD / 1100 / 3.15 / 40X6	1100	900	250	30	5
1962RD / 1150 / 3.15 / 40X6	1150	900	250	30	5
1962RD / 1200 / 3.15 / 40X6	1200	1000	250	30	5
1962RD / 1250 / 3.15 / 40X6	1250	1000	250	30	5
1962RD / 1300 / 3.15 / 40X6	1300	1120	280	35	6
1962RD / 1350 / 3.15 / 40X6	1350	1120	280	35	6
1962RD / 1400 / 3.15 / 40X6	1400	1120	280	35	6
1962RD / 1450 / 3.15 / 40X6	1450	1120	280	30	6
1962RD / 1500 / 3.15 / 40X6	1500	1120	280	35	6

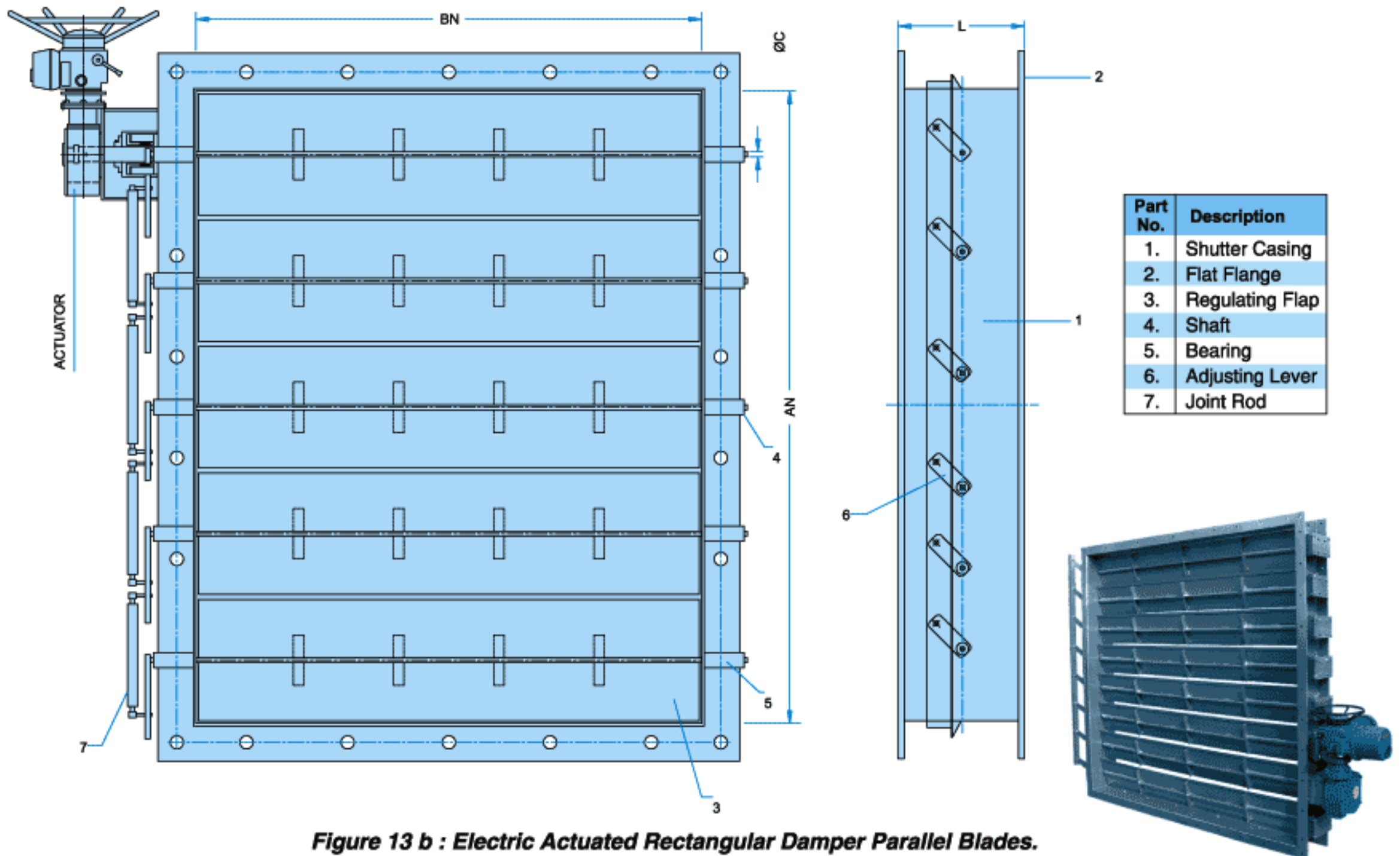

Figure 13 b : Electric Actuated Rectangular Damper Parallel Blades.

MODEL NO.	NOMINAL SIZE		L in mm	C in mm	NO. OF BLADES
	AN in mm	BN in mm			
1952RD / 100 / 3.15 / 40X6	100	125	140	15	1
1952RD / 150 / 3.15 / 40X6	150	125	140	15	1
1952RD / 200 / 3.15 / 40X6	200	160	200	15	1
1952RD / 250 / 3.15 / 40X6	250	200	250	15	1
1952RD / 300 / 3.15 / 40X6	300	250	180	20	2
1952RD / 350 / 3.15 / 40X6	350	280	180	20	2
1952RD / 400 / 3.15 / 40X6	400	315	200	20	2
1952RD / 450 / 3.15 / 40X6	450	335	225	20	2
1952RD / 500 / 3.15 / 40X6	500	400	250	20	2
1952RD / 550 / 3.15 / 40X6	550	450	200	25	3
1952RD / 600 / 3.15 / 40X6	600	500	225	25	3
1952RD / 650 / 3.15 / 40X6	650	500	225	25	3
1952RD / 700 / 3.15 / 40X6	700	560	250	25	3
1952RD / 750 / 3.15 / 40X6	750	600	280	20	3
1952RD / 800 / 3.15 / 40X6	800	630	200	20	4
1952RD / 850 / 3.15 / 40X6	850	630	200	25	4
1952RD / 900 / 3.15 / 40X6	900	710	225	25	4
1952RD / 950 / 3.15 / 40X6	950	710	225	25	4
1952RD / 1000 / 3.15 / 40X6	1000	800	250	25	4
1952RD / 1050 / 3.15 / 40X6	1050	800	250	30	4
1952RD / 1100 / 3.15 / 40X6	1100	900	250	30	5
1952RD / 1150 / 3.15 / 40X6	1150	900	250	30	5
1952RD / 1200 / 3.15 / 40X6	1200	1000	250	30	5
1952RD / 1250 / 3.15 / 40X6	1250	1000	250	30	5
1952RD / 1300 / 3.15 / 40X6	1300	1120	280	35	6
1952RD / 1350 / 3.15 / 40X6	1350	1120	280	35	6
1952RD / 1400 / 3.15 / 40X6	1400	1120	280	35	6
1952RD / 1450 / 3.15 / 40X6	1450	1120	280	30	6
1952RD / 1500 / 3.15 / 40X6	1500	1120	280	35	6

Note: Rectangular damper more popularly available in Multi Louver construction, they are also available in the form of Butterfly known as Rectangular Butterfly damper, for further details please contact us.

The dimensional details [13a, 13b] mentioned is considering Body and Flap thickness of 3.15 mm and Flange width of 40x6, for parallel blades, other options are available on request.

How to Order :

	Description	Model Number Creation
Type of Actuator	Pneumatic With model no.	1962 [P40]
Type of damper	Rectangular Multi Louver	RD
Damper size	in mm	1900x1900
Damper Length	in mm	300
Body Material	Mild Steel	MS
Disc Material	Mild Steel	MS
Body thickness	in mm	3.15
Disc thickness	in mm	6.0
Flange details		50x8
Temperature	Maximum	300°C
Characteristic	Proportional	LNN
Leakage class	98%	98
Proximity switches	2 nos	2PS
Electro Pneumatic Positioner	Siemens make	SP
Position transmitter	4-20mA output	PT
FRL Unit	Shavo/Norgen Of ¼"	FRL

Hence the final model number under Pneumatic will be

1962RD / 1900x1900 / 300/MS / MS / 3.15 / 6.0 / 50x8 / P40 / LNN / SB / 2PS / SP / PT / FRL

	Description	Model Number Creation
Type of Actuator	Motorized With model no.	1952 [SD-4000-20-WG200]
Type of damper	Rectangular multi louver	RD
Damper size	in mm	1900x1900
Damper Length	in mm	300
Body Material	Mild Steel	MS
Disc Material	Mild Steel	MS
Body thickness	in mm	6.0
Disc thickness	in mm	8.0
Flange details		50x8
Temperature	Maximum	300oC
Characteristic	Proportional	LNN
Leakage class	98%	98
Extra switches	2 nos	2AS
Electronic Positioner	with panel	WCP
Position transmitter	4-20mA output	PT

Hence the final model number under Motorized will be

1952RD / 1900x1900 / 300 / MS / MS / 6.0 / 8.0 / 50x8 / SD - 4000 - 20WG - 200 / LNN / 98 / 2AS / WCP / PT

For opposite blades please contact us for more information.

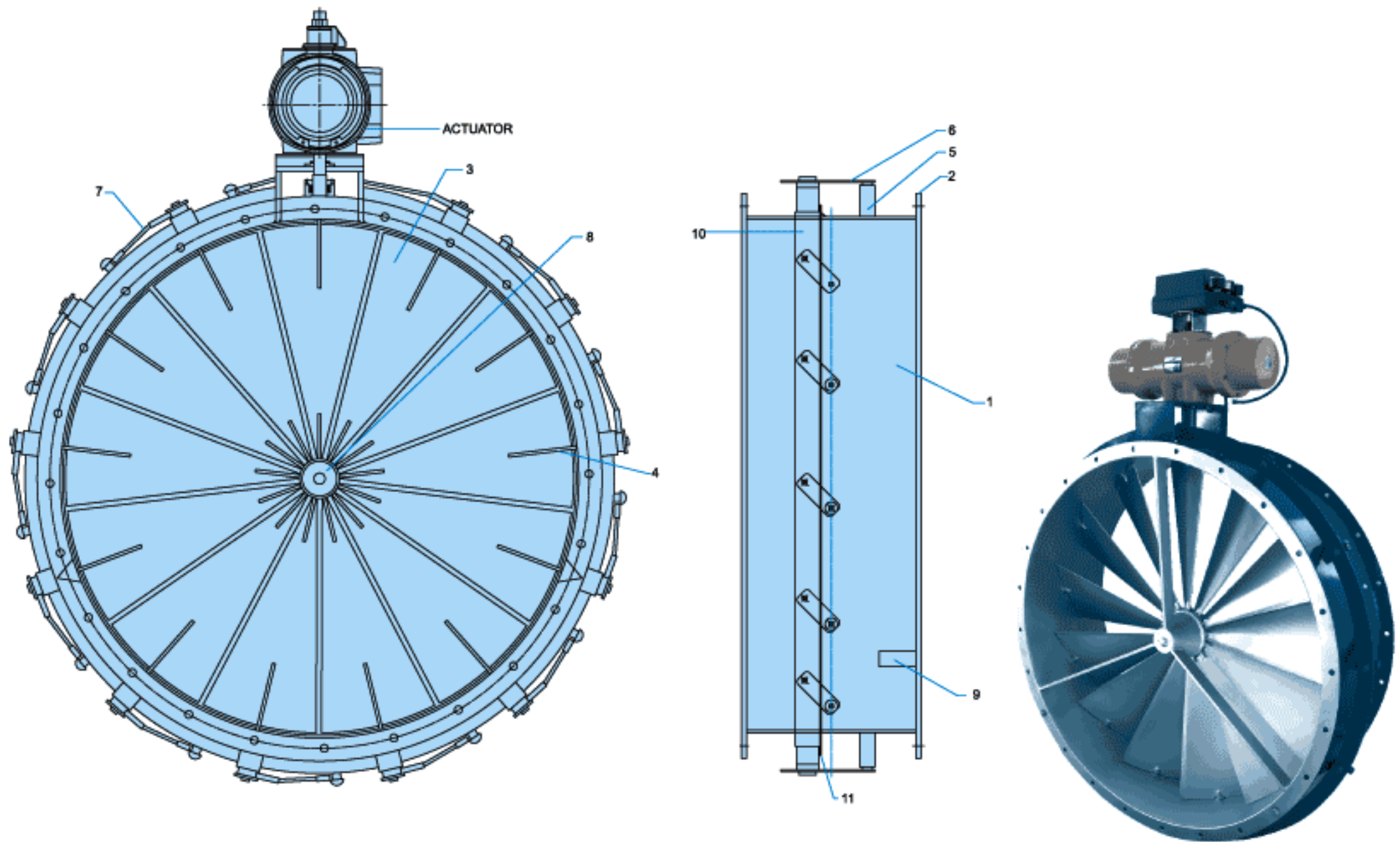

Figure 15 a : PNEUMATIC ACTUATED VIV DAMPER.

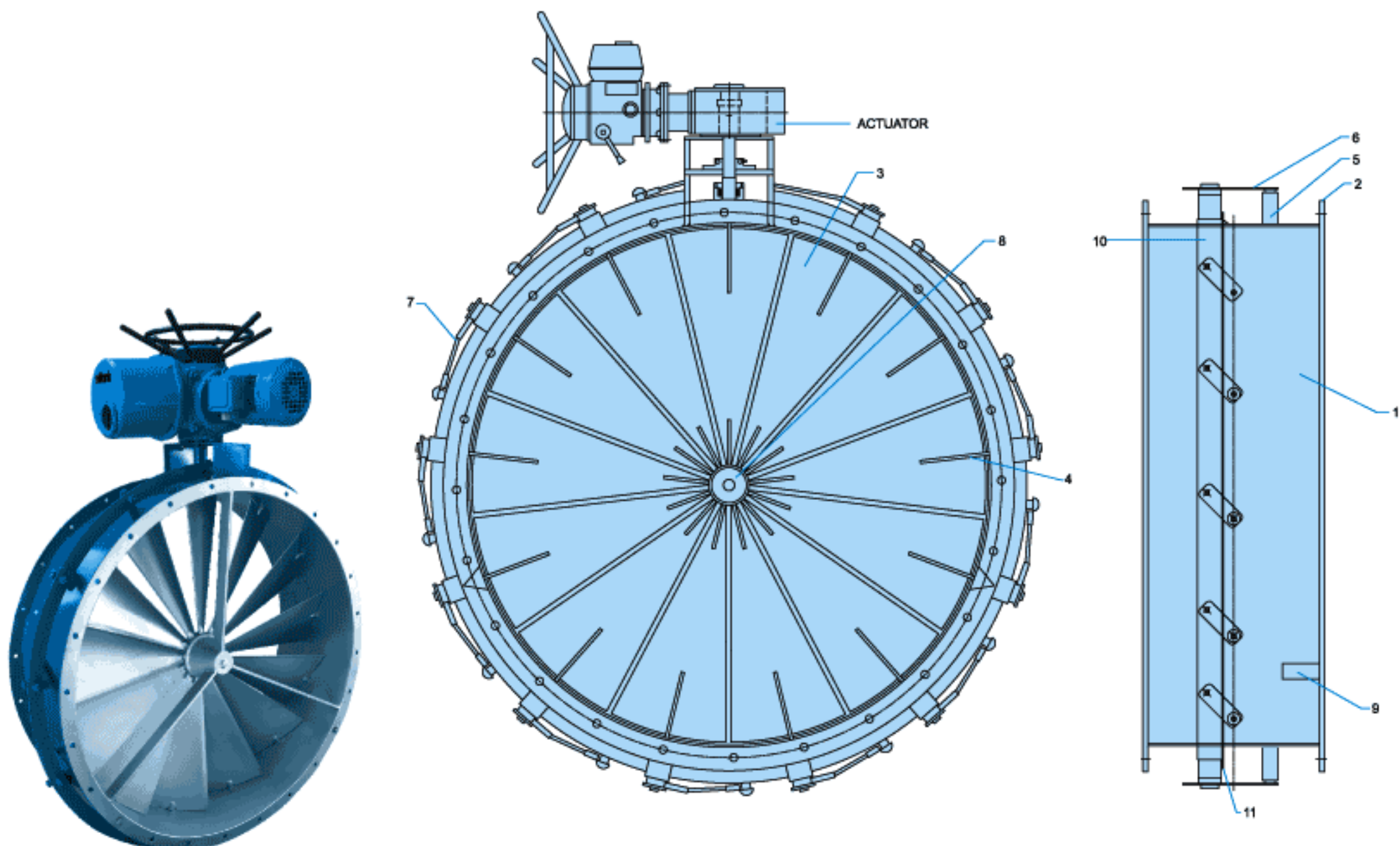
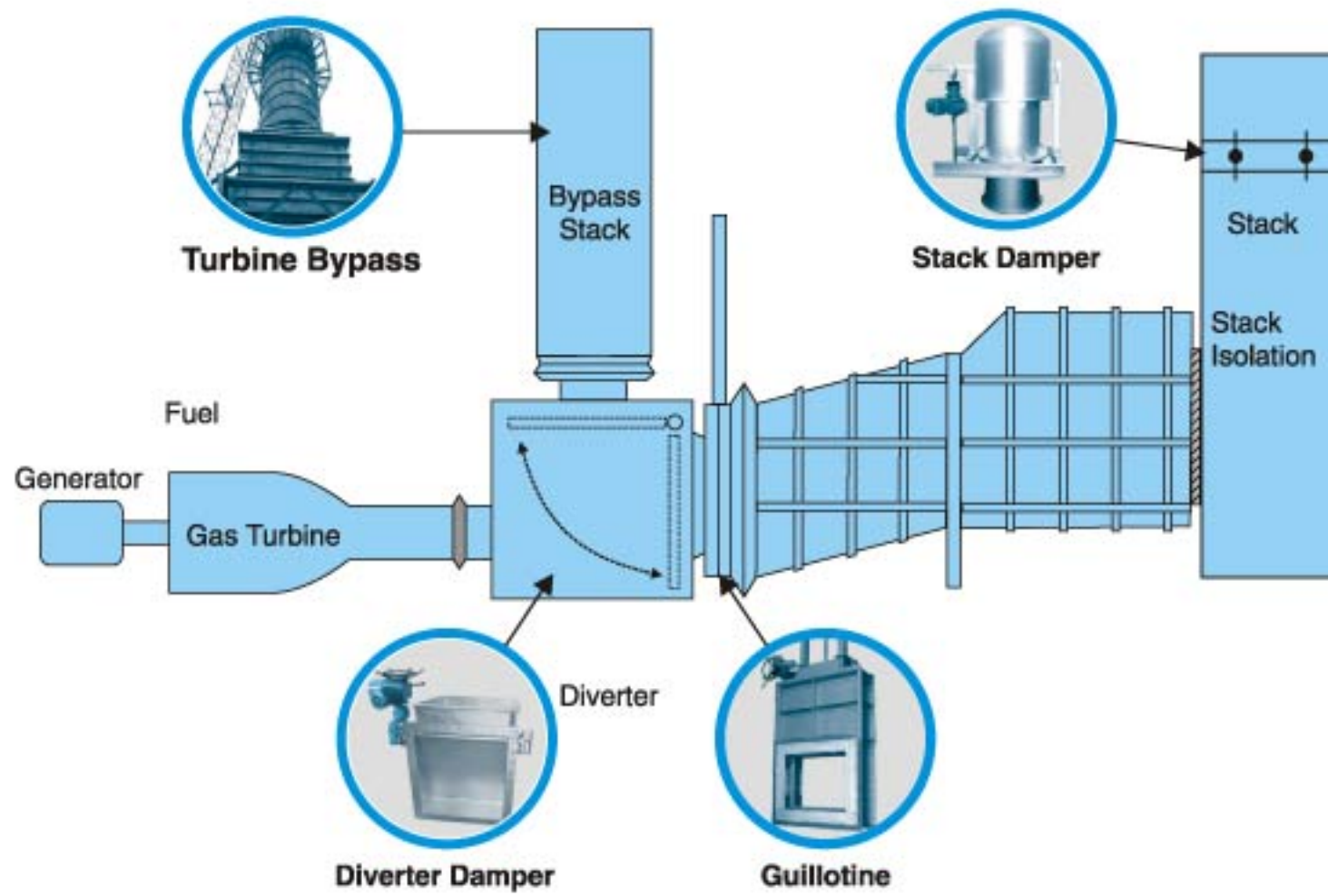

Figure 15 b : ELECTRIC ACTUATED VIV DAMPER.

- | | | | |
|-----------------|---------------------|-----------------|---------------------|
| 1. Guide Casing | 4. Shaft | 7. Joint Rod | 10. Conector Coller |
| 2. Flat Flange | 5. Bearing | 8. Center Guide | 11. Guide Roller |
| 3. Guide Blade | 6. Adjusting Leaver | 9. Support | |



Co-Generation System

- Tandem Louver (Leak less)
- Guillotine (Isolation)
- Stack (Multi Purpose)
- Louver (Economizer Bypass Line)
- Butterfly (Elecentric & Tandem)
- Metallic Expansion Joint

Conventional Power System

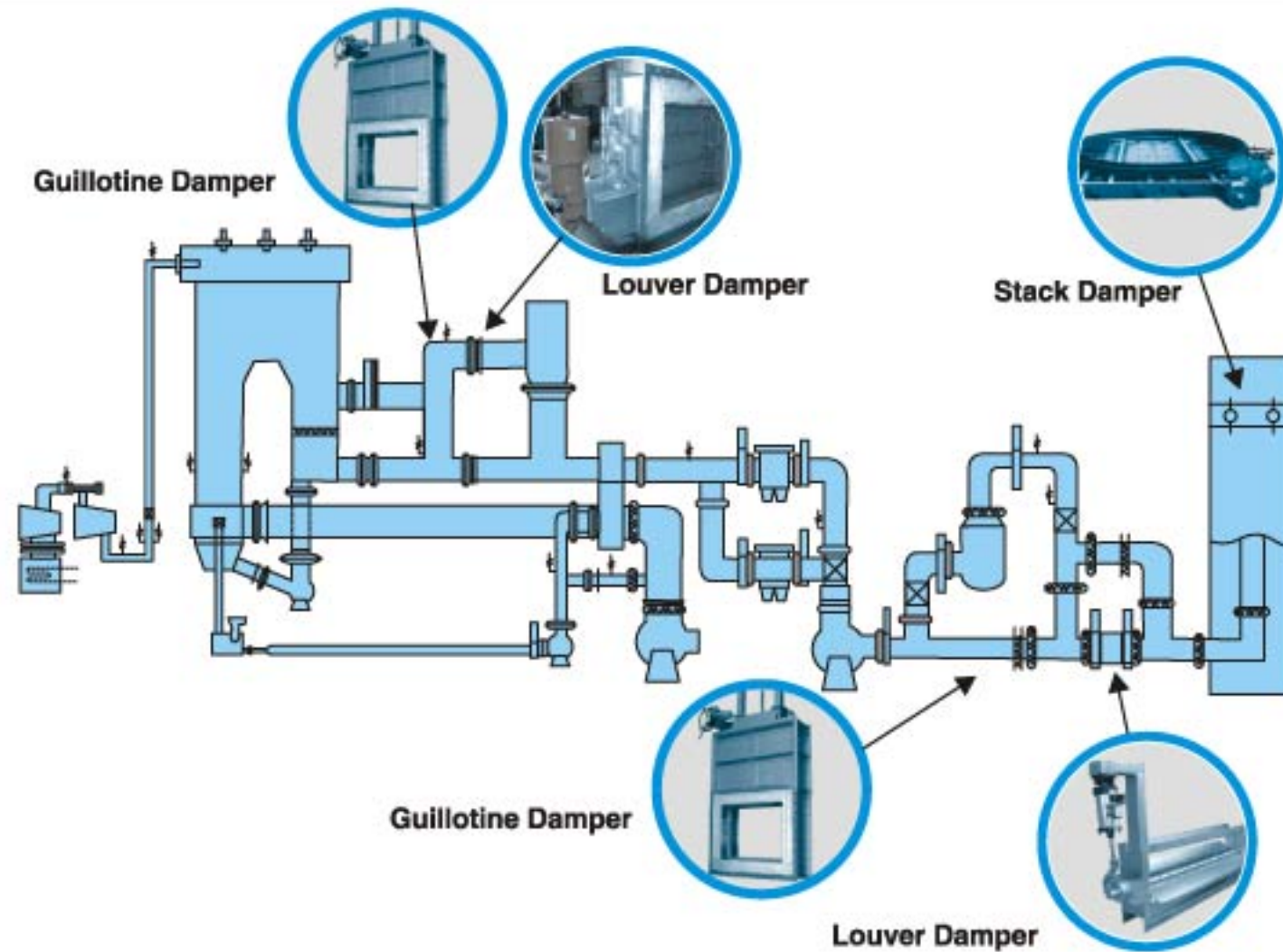

- Diverter (Leak less - Seal Air)
- Guillotine (Repair or Blanking)
- Stack (Multi Purpose)
- Double Louver (Isolation Stack)
- Fabric Expansion Joint
- Turbine Bypass System

Test & Inspection

Division	Items	Testing	Remarks
Basic Test	Dimension Verification	On Shop	-
	Surface Preparation Examination	On Shop	SSPC
	Paint Thickness Verification	On Shop	-
Damper	Bending / Deflection Test	On Shop	-
	Operational / Functional Test	On Shop	-
	Leakage Verification (Pressure Test)	On Shop	ANSI/FCI 70-2
	Seal Air Test	On Shop	AMGA 500
NDE	Liquid Penetration Testing	On Shop	-
	Radiographics Testing	Outsourced	-
	Ultrasound Testing	Outsourced	-

Actuators



Pneumatic Actuators



Electrical Actuators

Accessories



Filter Regulator & Lubricator



Solenoid Valve



Limit Switch Box



Positioner



Positioner - Servo Controller



Control Panel



Linkage



Position Transmitter





OUR OTHER PRODUCTS



- Solenoid Valves.
- Pneumatically operated Control Valves.
- Motorised Valves.
- Pneumatic & Electric Operated Ball / Butterfly valves.
- Pneumatic & Motorised Dampers.
- Pneumatic & Motorised VIV Dampers.
- Motorised Rising & Non-rising Sluice Valve.

- Heavy duty – Single phase & Three phase actuators for operating Gates & Chutes.
- Pneumatic & Motorised Pinch Valve.
- Pneumatic & Motorised Flush Bottom Valve.
- Entire range of Electrical Actuator.
- And Instrumentation Product likes Pressure Transmitter, PID Controller, Flow meter etc., for System Integration.



NOTE : TECHNICAL SPECIFICATIONS, DETAILS & DIMENSIONS ARE SUBJECT TO CHANGE WITHOUT PRIOR NOTICE. DIMENSIONS IN THE TABLE ARE APPROXIMATE SUBJECT TO FINAL CONFIRMATION BY SUDE.

Head Office, Bangalore

SUDE

An ISO 9001:2008 Certified Company

SUDE ENGINEERING CORPORATION

No. 1106, 10th Main Road, R.P.C. Layout,
Near R.P.C. Layout Bus Stop, Hampinagar,
Bangalore - 560 104. Karnataka, India

Tel. : +91 80 2330 2145 / 2314 1104 / 2340 2297

Fax : +91 80 2330 5729

Cell : +91 9845018216

E-mail : sudeengg@gmail.com ■ sudeengg@dataone.in

Web : www.sudeengg.com

Pune Office :

S.No. 40/4, Balaji Udyam Nagar, Tempo Chowk,
Wadgaon Sheri, Pune 411014. Maharashtra India.

Tel. : +91 20 6533 3549 / 6531 1091

Fax : +91 20 2703 1161

Cell : +91 9822980003

E-mail : scpl@sdtork.com

Web : www.sdtork.com